



Geotextile Sand Filter

New Mexico
Design & Installation Manual



eljen
CORPORATION

Innovative Onsite Products & Solutions Since 1970

June 2018

www.eljen.com

Table of Contents

SUBJECT	PAGE
GLOSSARY OF TERMS.....	3
GSF SYSTEM DESCRIPTION	4
1.0 SYSTEM PRECONDITIONS	5
2.0 DESIGN AND INSTALLATION	6
3.0 TRENCH INSTALLATION SIZING AND GUIDELINES.....	11
4.0 BED INSTALLATION SIZING AND GUIDELINES	14
5.0 MOUND INSTALLATION GUIDELINES.....	17
6.0 DOSING DISTRIBUTION GUIDANCE	19
7.0 PRESSURE DISTRIBUTION GUIDANCE.....	19
8.0 PUMP CONTROLS.....	21
9.0 SYSTEM VENTILATION.....	22
10.0 GSF INSPECTION CHECK LIST	23
GSF DRAWINGS AND TABLES	
DRAWINGS	
FIGURE 1: GSF SYSTEM OPERATION.....	4
FIGURE 2: TYPICAL A42 CROSS SECTION	6
FIGURE 3: TYPICAL B43 CROSS SECTION	6
FIGURE 4: VERTICAL SEPARATION DISTANCE	7
FIGURE 5: SEQUENTIAL DISTRIBUTION DROP-BOX DETAIL.....	8
FIGURE 6: PLAN VIEW – A42 TRENCH SYSTEM EXAMPLE	12
FIGURE 7: SECTION VIEW – A42 TRENCH SYSTEM EXAMPLE – LEVEL SITE.....	12
FIGURE 8: SECTION VIEW – A42 TRENCH SYSTEM – SLOPING SITE.....	12
FIGURE 9: PLAN VIEW – B43 BED SYSTEM EXAMPLE – LEVEL SITE	15
FIGURE 10: SECTION VIEW – BED SYSTEM EXAMPLE	15
FIGURE 11: INSTALLING ABOVE NATURAL SOIL GRADE	17
FIGURE 12: CROSS SECTION – SLOPED MOUND SYSTEM.....	17
FIGURE 13: PRESSURE PIPE PLACEMENT	20
FIGURE 14: PRESSURE CLEAN OUT	20
FIGURE 15: CONTOURED TRENCH PRESSURE DISTRIBUTION.....	21
FIGURE 16: VENT LAYOUTS FOR GRAVITY AND LOW-PRESSURE SYSTEMS.....	22
FIGURE 17: GSF WITH 4" VENT EXTENDED TO CONVENIENT LOCATION.....	22
TABLES	
TABLE 1: SPECIFIED SAND SIEVE REQUIREMENTS.....	3
TABLE 2: NUMBER OF MODULES REQUIRED PER DESIGN FLOW	10
TABLE 3: APPLICATION RATES FOR TRENCH AND BED DESIGNS.....	10

Glossary of Terms

A42 Module	48" x 24" x 7" (L x W x H)
B43 Module	48" x 36" x 7" (L x W x H)
Cover Fabric	The geotextile cover fabric (provided by manufacturer) that is placed over the GSF modules.
Design Flow	<p>For residential sources, the design flow shall be based on the number of bedrooms as follows:</p> <ul style="list-style-type: none"> a) 1 bedroom = 150 gallons per day; b) 2 bedrooms = 300 gallons per day; c) 3 bedrooms = 375 gallons per day; d) 4 bedrooms = 440 gallons per day; e) 5 bedrooms = 500 gallons per day; and f) each additional bedroom = 50 gallons per day; g) design flows for multiple family dwelling units shall be calculated as the sum of design flows for each single-family unit included. <p>Based on 20.7.3.201 NMAC, P (1).</p>
Flow Dial/Equalizer	Special insert placed in the end of distribution pipes within the distribution box to compensate for possible unlevel installation and promote favorable flow to the distribution pipes.
GSF	The Eljen Geotextile Sand Filter Modules and the 6-inch sand layer at the base and the 12-inch layer along the sides of the modules.
GSF Module	The individual module of a GSF system. The module is comprised of a cusped plastic core and geotextile fabric.
Serial or Sequential Distribution	Designs common to sloping sites where GSF lines are laid on the contour, receiving effluent from a series of Drop-Boxes starting at upper Modified Trench / Line and overflows effluent when required to down-slope Modified Trenches / Lines.
Specified Sand	To ensure proper system operation, the system MUST be installed ASTM C33 SAND. Sand must be used with not more than 10% passing the #100 Sieve and not more than 5% passing the # 200 sieve. Ask your material supplier for a sieve analysis to verify that your material meets the required specifications.

TABLE 1: SPECIFIED SAND SIEVE REQUIREMENTS

ASTM C33 SAND SPECIFICATION		
Sieve Size	Sieve Square Opening Size	Specification Percent Passing (Wet Sieve)
3/8 inch	9.52 mm	100
No. 4	4.76 mm	95 - 100
No. 8	2.38 mm	80 - 100
No. 16	1.19 mm	50 - 85
No. 30	590 µm	25 - 60
No. 50	297 µm	10 - 30
No. 100	149 µm	< 10
No. 200	75 µm	< 5

GSF System Description

Primary Treatment Zone

- Perforated pipe is centered above the GSF module to distribute septic effluent over and into corrugations created by the cusped core of the geotextile module.
- Septic effluent is filtered through the Bio-Matt fabric. The module's unique design provides increased surface area for biological treatment that greatly exceeds the module's footprint.
- Open air channels within the module support aerobic bacterial growth on the modules geotextile fabric interface, surpassing the surface area required for traditional absorption systems.
- An anti-siltation geotextile fabric covers the top and sides of the GSF module and protects the Specified Sand and soil from clogging, while maintaining effluent storage within the module.

Secondary Treatment Zone

- Effluent drips into the Specified Sand layer and supports unsaturated flow into the native soil. This Specified Sand/soil interface maintains soil structure, thereby maximizing the available absorption interface in the native soil. The Specified Sand supports nitrification of the effluent, which reduces oxygen demand in the soil, thus minimizing soil clogging from anaerobic bacteria.
- The Specified Sand layer also protects the soil from compaction and helps maintain cracks and crevices in the soil. This preserves the soil's natural infiltration capacity, which is especially important in finer textured soils, where these large channels are critical for long-term performance.
- Native soil provides final filtration and allows for groundwater recharge.

FIGURE 1: GSF SYSTEM OPERATION

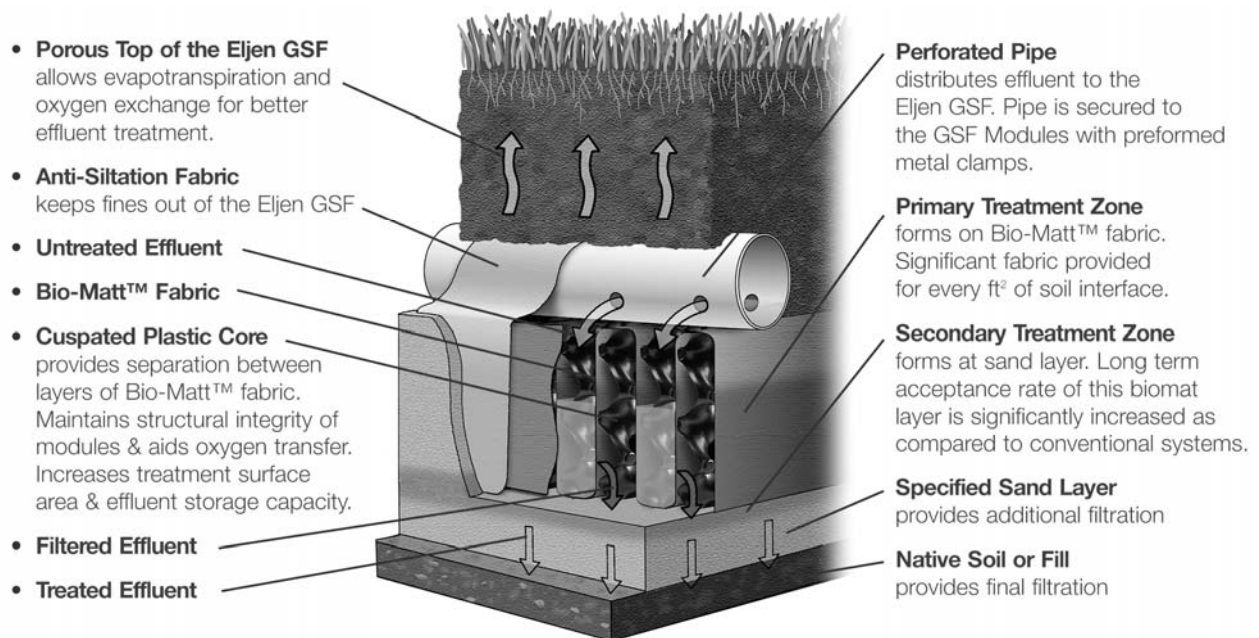

1.0 System Preconditions

1.1 REQUIREMENTS: GSF subsurface treatment must meet Title 20, Chapter 7, Part 3 of the New Mexico Administrative Code, except as outlined in this manual.

The sizing information in Sections 2.15 – 2.19 of this manual applies to residential systems only. Please contact *Eljen's Technical Resource Department at 1-800-444-1359* for design information on commercial systems.

1.2 WATER SOFTENER BACKWASH: At no time should water softener backwash be disposed of in the septic system. Water softener backwash should be discharged to a separate soil absorption field.

1.3 GARBAGE DISPOSALS: Eljen discourages the use of garbage disposals with septic systems. If a GSF system is to be designed and installed with garbage disposals the following measures must be taken to prevent solids from leaving the tank and entering the GSF system:

- Increasing the septic tank capacity by a minimum of 30%, or
- Installation of a second septic tank installed in series, or
- Installation of an appropriate sized septic tank outlet effluent filter.

Eljen requires the use of septic tank outlet effluent filters on all systems especially on those systems that have single compartment tanks, even if up-sized, and when the dwelling has a garbage disposal installed.

1.4 ADDITIONAL FACTORS AFFECTING RESIDENTIAL SYSTEM SIZE: Homes with expected higher than normal water usage may consider increasing the septic tank volume as well as incorporating a multiple compartment septic tank. Consideration for disposal area may be up-sized for expected higher than normal water use.

For example:

- Luxury homes, homes with a Jacuzzi style tubs, and other high use fixtures.
- Homes with known higher than normal occupancy.

1.5 SYSTEM PROHIBITED AREAS: All vehicular traffic is prohibited over the GSF system. GSF systems shall not be installed under paved or concreted areas. If the system is to be installed in livestock areas, the system must be fenced off around the perimeter to prevent compaction of the cover material and damage to the system.

FIGURE 2: TYPICAL A42 CROSS SECTION

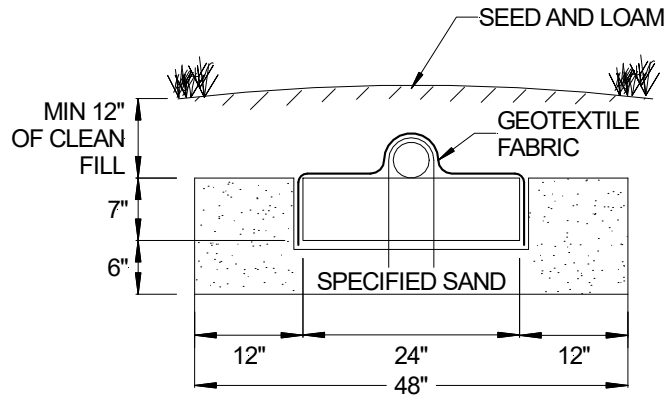

A42 MODULE (L x W x H) 48" x 24" x 7"

FIGURE 3: TYPICAL B43 CROSS SECTION

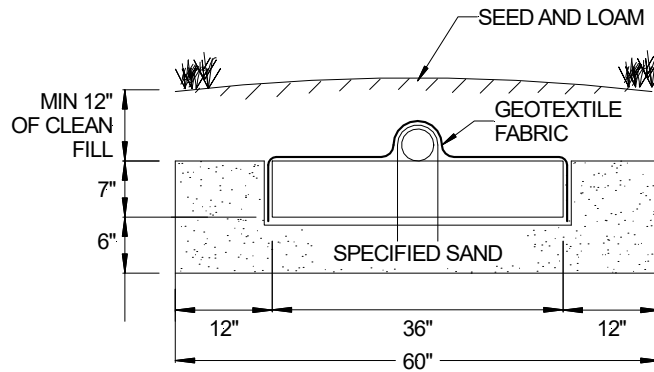

B43 MODULE (L x W x H) 48" x 36" x 7"

All systems are required to have a minimum of:

- 12 inches of Specified Sand is at the edges of the GSF module.
- 12 inches of Specified Sand is at the beginning and end of each GSF Row.
- 6 inches of Specified Sand is directly below the GSF module.
- Minimum 12 inches of cover above the module.

2.0 Design and Installation

2.1 SEPTIC TANK: Septic tanks should be fitted with an effluent filter and sized according to state regulations. Refer 20.7.3.502 NMAC for further guidelines.

2.2 SEPTIC TANK FILTERS: Septic tank effluent filters are **REQUIRED** on the outlet end of septic tank. Filter manufactures require that filters be cleaned from time to time. Ask your installer or designer for specific cleaning requirements based on the type or make of the filter installed. Eljen requires the septic tank to be pumped every three years or as needed which would be a good time to check and conduct filter maintenance.

2.3 SEASONAL HIGH-WATER TABLE: Reduction in vertical separation may be allowed by your approving authority in accordance with 20.7.3.303 NMAC, B.

FIGURE 4: VERTICAL SEPARATION DISTANCE

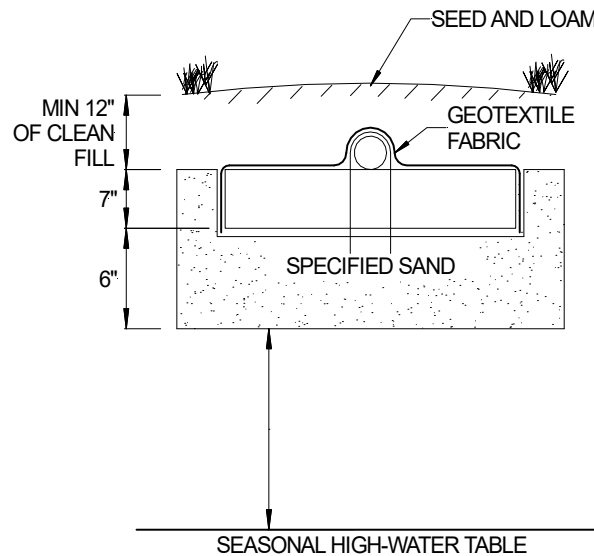

2.4 SPECIFIED SAND SPECIFICATION FOR GSF SYSTEMS: The first 6 inches of Specified Sand immediately under and the 12 inches between rows and around the perimeter of the GSF system must be an **ASTM C33 WASHED CONCRETE SAND WITH LESS THAN 10% PASSING A #100 SIEVE AND LESS THAN 5% PASSING A #200 SIEVE**. Please place a prominent note to this effect on each design drawing. See Table 1 for more information on the ASTM C33 sand and sieve specifications.

2.5 PLACING GSF MODULES: The "painted stripe" on the GSF modules indicates the top of the module and is not intended to indicate the location of the distribution pipe. With the painted stripe facing up, all rows of GSF modules are set level, end to end on the Specified Sand layer.

2.6 DISTRIBUTION: Gravity, pump to gravity or pressure distribution are acceptable when using the GSF System. Piping shall meet the requirements guidelines; however, Eljen strongly recommends the use of SDR 35 pipe and fittings as to prevent crushing during backfill. All distribution piping must meet a minimum 2,500-pound crush test specification for polyvinyl chloride (PVC) drain, waste and vent pipe.

All systems require a perforated 4" diameter pipe centered on top of the GSF modules unless the system is curving. The distribution pipe continues along the entire length of all modules in a trench or row. Holes are set at the 4 and 8 o'clock position and secured by the Eljen provided wire clamps.

When using pressure distribution, a pressure manifold is placed inside the 4-inch distribution pipe. Section 7 of this manual goes into details of how to construct the distribution network. All piping must meet state and local regulations.

2.0 Design and Installation

2.7 CONNECTIONS AND FITTINGS: Connections of lines to tanks and distribution boxes must be made using watertight seals. Use of any grouting material is not permitted.

2.8 DISTRIBUTION BOX: Set the gravity system D-box outlet invert a minimum of $\frac{1}{8}$ inch drop in elevation per linear foot to the top first module in the row. Set a 2-inch minimum drop for dosed systems from the D-box to the modules. Ensure that the distribution box and pipes feeding the system are placed on compacted soil. Flow Dials may be used in either Gravity or Dosed installations.

2.9 INSTALLING ON SLOPING TERRAIN: For trench systems, edge-to-edge spacing will be a minimum of 4 feet. For bed systems, edge-to-edge minimum spacing will be 2 feet.

Provide a D-box at the beginning of the first row of modules for effluent distribution and velocity reduction and as a system inspection port. Lower rows may also be loaded from one or more D-boxes with Flow Dials to insure effluent is distributed per design requirements. Serial or equal distribution is permitted.

Equal Distribution: Set Flow Dials to insure effluent is distributed equally to all rows in the system.

Serial Distribution: Set Flow Dials to insure effluent is loaded to the upslope trench first before continuing to lower trenches within the system.

2.9 EQUAL DISTRIBUTION: Parallel distribution is the preferred method of dosing to a gravity or pump to gravity system. It encourages equal flows to each of the lines in the system. It is recommended for most trench systems.

2.10 SEQUENTIAL DISTRIBUTION: Sequential Distribution using a distribution box will fully utilize the uppermost section of the system prior to spilling effluent into a lower row of modules. This is for use on any site with greater than 0.5% slope when not using parallel distribution.

FIGURE 5: SEQUENTIAL DISTRIBUTION DROP-BOX DETAIL

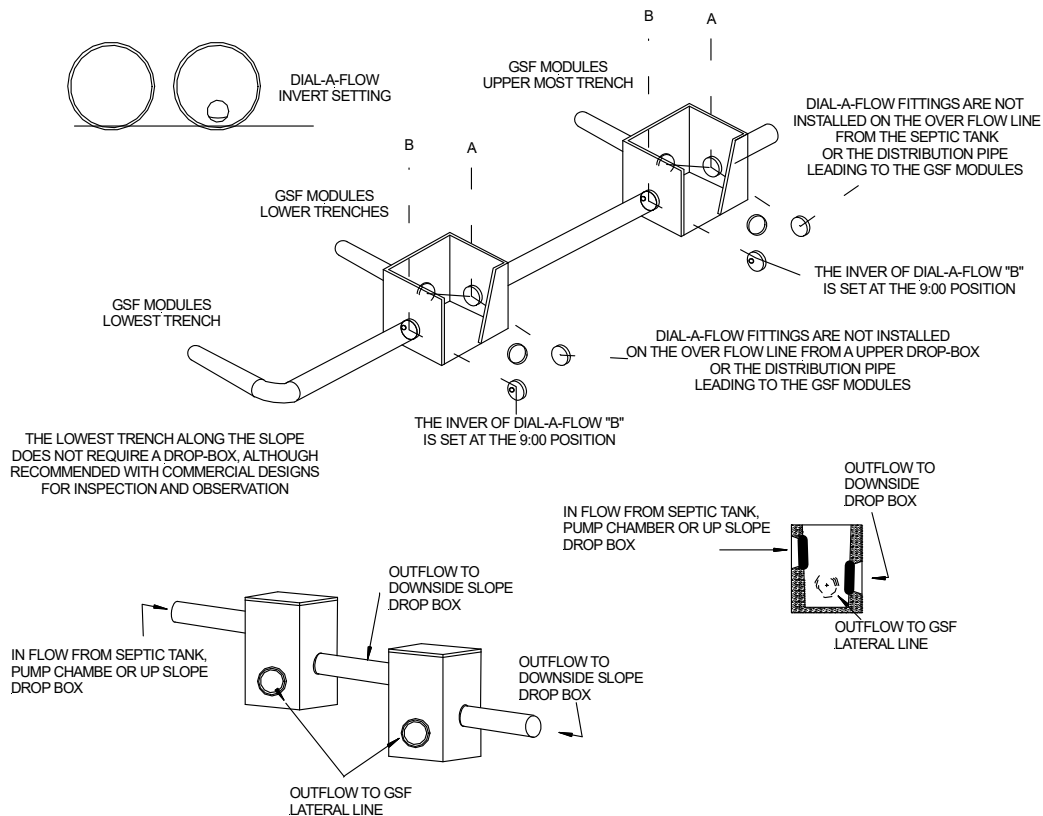

2.0 Design and Installation

2.11 COVER FABRIC: Geotextile cover fabric is provided by Eljen Corporation for all GSF systems. It is placed over the top and sides of the module rows to prevent long term siltation and failure. **Cover fabric substitution is not allowed.** Fabric should drape vertically over the pipe and must not block holes in the distribution pipe or be stretched from the top of the pipe to the outside edge of the modules. “Tenting” will cause undue stress on fabric and pipe.

2.12 SYSTEM VENTING: It is required to vent all systems that are over 18” below finished grade and systems beneath any surface condition that would not allow for surface air exchange with the system such as patios. See Section 9.0 for a more detailed explanation of venting GSF products.

2.13 BACKFILL & FINISH GRADING: Complete backfill with a minimum of 12 inches of clean porous fill measured from the top of modules. Use well graded sandy fill that is clean, porous and devoid of large rocks. Do not use wheeled equipment over the system. A light track machine may be used with caution, avoiding crushing or shifting of pipe assembly. Divert surface runoff from the system absorption area. Finish grade to prevent surface ponding. Seed and loam system area to protect from erosion.

2.14 SYSTEM GEOMETRY: Design systems as long and narrow as practical along site contours to minimize ground water mounding especially in poorly drained low permeability soils. If possible, design level systems with equal number of modules per row.

There is a minimum 4-foot separation between trenches, measured from sidewall to sidewall.

In bed and trench systems, it is acceptable to space the units to maximize points of application to the basal area.

2.15 BED SYSTEMS: Bed systems require a minimum of 2 rows and Eljen recommends a maximum lateral to lateral spacing of 12 feet.

2.16 NUMBER OF GSF MODULES REQUIRED: Calculations on how to determine the number of GSF module for residential systems use are based on the following information:

- a maximum loading rate of 30 gallons per day per module for B43 modules;
- a maximum loading rate of 25 gallons per day per module for A42 modules;
- a minimum of 5 B43 Modules per bedroom; or
- a minimum of 6 A42 Modules per bedroom.

2.17 SIZING GSF SYSTEM FOR TRENCHES, BEDS & SAND MOUNDS: When determining the correct sizing for your GSF system, it is important to follow your local codes and regulations for proper surface and subsurface classifications.

2.0 Design and Installation

2.18 SIZING CHARTS:

TABLE 2: NUMBER OF MODULES REQUIRED PER DESIGN FLOW

Bedrooms	1	2	3	4	5	6	7
gpd	150	300	375	440	500	550	600
Number of Modules Required for A42	6	12	18	24	30	36	42
Number of Modules Required for B43	5	10	15	20	25	30	35

TABLE 3: APPLICATION RATES FOR TRENCH AND BED DESIGNS

Soil Type	Soil Texture	Application Rate (AR) (sq. ft./gal/day)	
		Trench	Bed
Ia	Coarse Sand or up to 30% Gravel	0.88	1.31
Ib	Medium sand, Loamy sand	1.40	2.10
II	Sandy Loam, Fine sand, Loam	1.40	2.10
III	Silt, Silt Loam, Clay Loam, Silty Clay Loam, Sandy Clay Loam	1.40	2.10
IV	Sandy Clay, Silty Clay, Clay	3.50	5.25

2.19 DESIGN NOTE: All systems must meet the requirements of 2.15 and 2.16 or 2.17. The system must have the minimum number of units and it must have the minimum footprint required. Some designs will require additional modules or bottom area to meet these requirements.

3.0 Trench Installation Sizing and Guidelines

Trench Example:

House size: 4 Bedrooms
 Daily Design Flow: 440 gpd
 Soil Type: III

Minimum Number of Units

Lookup the information required from Table 2:

Bedrooms	1	2	3	4	5	6	7
gpd	150	300	375	440	500	550	600
Number of Modules Required for A42	6	12	18	24	30	36	42
Number of Modules Required for B43	5	10	15	20	25	30	35

A42: 24 Units B43: 20 Units

Application Rate

Lookup the information required from Table 3:

Soil Type	Soil Texture	Application Rate (AR) (sq. ft./gal/day)	
		Trench	Bed
III	Silt, Silt Loam, Clay Loam, Silty Clay Loam, Sandy Clay Loam	1.40	2.10

Minimum Trench Bottom required

$$\text{GPD} \times \text{Application Rate} = \text{Minimum Trench Bottom Area}$$

$$440 \text{ gpd} \times 1.40 \text{ ft}^2/\text{gal/day} = 616 \text{ ft}^2$$

Trench Width

A42: 4 ft B43: 5 ft

Calculate Minimum Trench Length

a) Units x 4 + 2 ft or b) Minimum Trench Bottom ÷ Trench Width

A42: a) 24 units x 4 + 2 ft = 98 ft B43: a) 20 units x 4 + 2 ft = 82 ft

A42: b) 616 ft² ÷ 4 ft = 154 ft B43: b) 616 ft² ÷ 5 ft = 123.2,

A42: round to 154 ft B43: round to 124 ft

Use the greater of a or b: 154 ft Use the greater of a or b: 124 ft

Calculate Excavation Open Sand

If a is used above, 2 ft

If b is used above, (b – a – 2)

A42: a) 2 ft B43: a) 2 ft

A42: b) (154 ft – 98 ft + 2) = 58 ft B43: b) (124 ft – 82 ft + 2) = 44 ft

Final Dimension Layout

(Note: System layout and number of rows will vary based on site constraints)

A42

Min. Trench Length	154 ft.
Trench Width	4 ft.
Excavation Open Sand	58 ft
Minimum Number of Units	24 A42s
System Area	616 ft ²

B43

Min. Trench Length	124 ft.
Trench Width	5 ft.
Excavation Open Sand	44 ft
Minimum Number of Units	20 B43s
System Area	616 ft ²

3.0 Trench Installation Sizing and Guidelines

FIGURE 6: PLAN VIEW – A42 TRENCH SYSTEM EXAMPLE

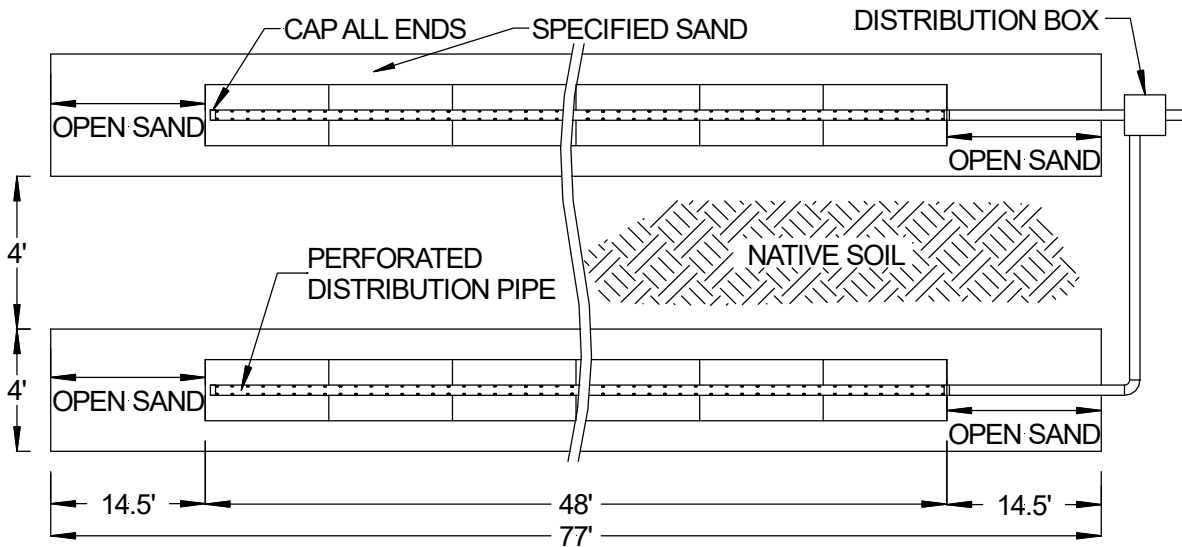

FIGURE 7: SECTION VIEW – A42 TRENCH SYSTEM EXAMPLE – LEVEL SITE

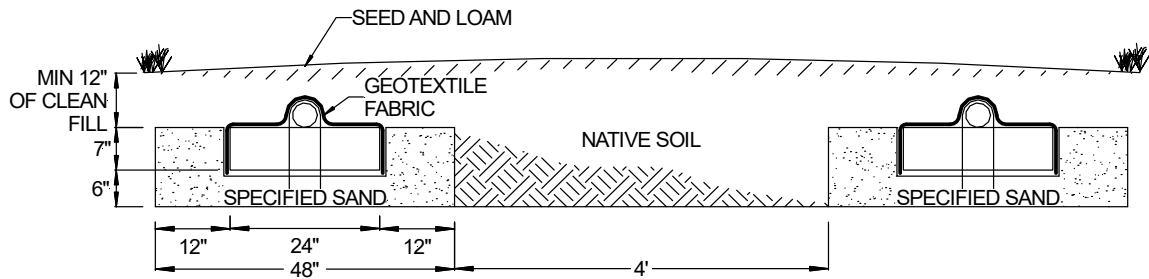
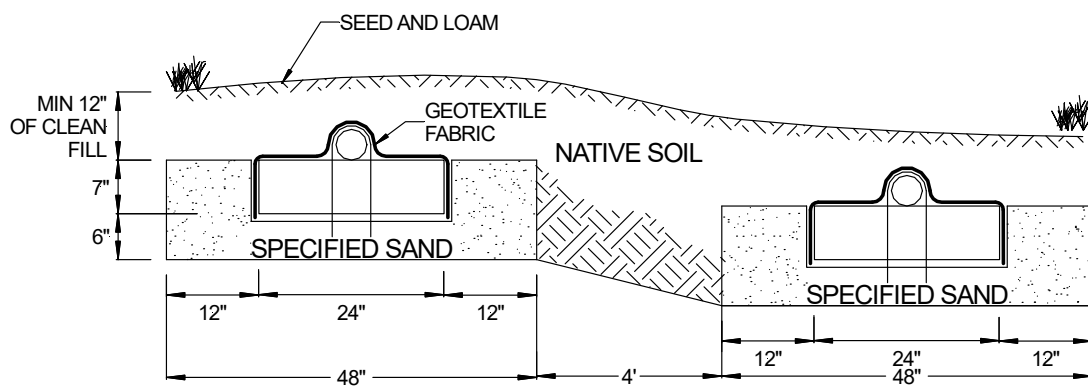

FIGURE 8: SECTION VIEW – A42 TRENCH SYSTEM – SLOPING SITE



3.0 Trench Installation Sizing and Guidelines

1. Ensure all components leading to the GSF system are installed properly. Septic tank effluent filters are required with the GSF system.
2. Determine the number of GSF Modules required using the trench sizing example.
3. Prepare the site. Do not install a system on saturated ground or wet soils that are smeared during excavation. Keep machinery off infiltrative areas.
4. Plan all drainage requirements above (up-slope) of the system. Set soil grades to ensure that storm water drainage and ground water is diverted away from the absorption area once the system is complete.
5. Excavate the trench; prepare the receiving layer to maximize the interface between the native soil and specified sand.
6. Minimize walking in the trench prior to placement of the specified sand to avoid soil compaction.
7. Place specified sand in a 6" lift and stabilize by foot, a hand held tamping tool or a portable vibrating compactor. The minimum stabilized height below the GSF module must be level at 6".
8. Place GSF modules with **PAINTED STRIPE FACING UP**, end to end on top of the specified sand along their 4-foot length.
9. A standard 4-inch perforated pipe, SDR 35 or equivalent, is centered along the modules 4-foot length. Orifices are set at the 4 & 8 o'clock position.
10. All 4-inch pipes are secured with manufacturers supplied wire clamps, one per module.
11. (Pressure Distribution Systems) Insert a pressure pipe (size per design and code) into the standard 4-inch perforated pipe. The pressure pipe orifices are set at the 12 o'clock position as shown in Figure 13. Each pressure lateral will have a drain hole at the 6 o'clock position. Each pressure lateral shall include sweeping cleanouts at the terminal ends and be accessible from grade.
12. **Cover fabric substitution is not allowed.** The installer should lay the Eljen provided geotextile cover fabric lengthwise down the trench, with the fabric fitted to the perforated pipe on top of the GSF modules. Fabric should be neither too loose, nor too tight. The correct tension of the cover fabric is set by:
 - a. Spreading the cover fabric over the top of the module and down both sides of the module with the cover fabric tented over the top of the perforated distribution pipe.
 - b. Place shovelfuls of Specified Sand directly over the pipe area allowing the cover fabric to form a mostly vertical orientation along the sides of the pipe. Repeat this step moving down the pipe.
13. Place the sand extensions along both sides of the modules edge. A minimum of 12 inches of Specified Sand is placed at the beginning and end of each trench.
14. Complete backfill with a minimum of 12 inches of clean porous fill measured from the top of the module. Backfill exceeding 18 inches requires venting at the far end of the trench. Use well graded native soil fill that is clean, porous and devoid of large rocks. Do not use wheeled equipment over the system. A light track machine may be used with caution, avoiding crushing or shifting of pipe assembly.
15. Divert surface runoff from the system. Finish grade to prevent surface ponding. Topsoil and seed system area to protect from erosion.

4.0 Bed Installation Sizing and Guidelines

Bed Example:

House size: 3 Bedrooms
 Daily Design Flow: 375 gpd
 Soil Type: III

Minimum Number of Units

Lookup the information required from Table 2:

Bedrooms	1	2	3	4	5	6	7
gpd	150	300	375	440	500	550	600
Number of Modules Required for A42	6	12	18	24	30	36	42
Number of Modules Required for B43	5	10	15	20	25	30	35

A42: 18 Units

B43: 15 Units

Application Rate

Lookup the information required from Table 3:

Soil Type	Soil Texture	Application Rate (AR) (sq. ft./gal/day)	
		Trench	Bed
III	Silt, Silt Loam, Clay Loam, Silty Clay Loam, Sandy Clay Loam	1.40	2.10

Minimum Trench Bottom required

GPD x Application Rate = Minimum Trench Bottom Area

$$375 \text{ gpd} \times 2.10 \text{ ft}^2/\text{gal/day} = 787.5, \text{ round up to } 788 \text{ ft}^2$$

Bed Width

Number of Rows x Desired Row Width (Recommend Max of 12 feet)

A42: 2 Rows x 10 feet 20 ft B43: 2 Rows x 8 ft 16 ft

Calculate Bed Length – Minimum 2 Rows

Minimum Absorption Area Required ÷ Bed Width

A42: $788 \text{ ft}^2 \div 20 \text{ ft} = 39.4 \text{ ft}$ B43: $788 \text{ ft}^2 \div 16 \text{ ft} = 49.25 \text{ ft}$
 A42: Round to 40 ft B43: Round to 50 ft

Calculate Unit Length

A42: $18 \text{ A42s} \div 2 \text{ Rows} = 9 \text{ A42s per Row}$ B43: $15 \text{ B43s} \div 2 \text{ Rows} = 7.5$
 A42: $9 \text{ A42s} \times 4 \text{ ft per A42} = 36 \text{ ft}$ B43: Round to 8 B43s per Row
 B43: $8 \text{ B43s} \times 4 \text{ ft per B43} = 32 \text{ ft}$

Determine Lateral Spacing

Lateral to Lateral Spacing = Bed Width ÷ Number of Rows

A42: $20 \text{ ft} \div 2 \text{ Rows} = 10 \text{ ft}$ B43: $16 \text{ ft} \div 2 \text{ Rows} = 8 \text{ ft}$

Lateral to Edge Spacing = Lateral to Lateral Spacing ÷ 2

A42: $10 \text{ ft} \div 2 = 5 \text{ ft}$ B43: $8 \text{ ft} \div 2 = 4 \text{ ft}$

Determine Module Spacing in Bed

(Bed Length – Unit Length) ÷ 2

A42: $(40 \text{ ft} - 36 \text{ ft}) \div 2 = 2 \text{ ft}$ B43: $(50 \text{ ft} - 32 \text{ ft}) \div 2 = 9 \text{ ft}$
 A42: Round to 2 ft B43: Round to 9 ft

4.0 Bed Installation Sizing and Guidelines

Final Dimension Layout

(Note: System layout and number of rows will vary based on site constraints)

A42

Bed Length	40 ft.
Bed Width	20 ft.
Minimum Number of Units	18 Units
Units per Row	9 units per row
Lateral to Lateral Spacing	10 ft.
Lateral to Edge Spacing	5 ft.
Edge of System to Module	2 ft.
System Area	800 ft ²

B43

Bed Length	50 ft.
Bed Width	16 ft.
Minimum Number of Units	16 Units
Units per Row	8 units per row
Lateral to Lateral Spacing	8 ft.
Lateral to Edge Spacing	4 ft.
Edge of System to Module	9 ft.
System Area	800 ft ²

FIGURE 9: PLAN VIEW – B43 BED SYSTEM EXAMPLE – LEVEL SITE

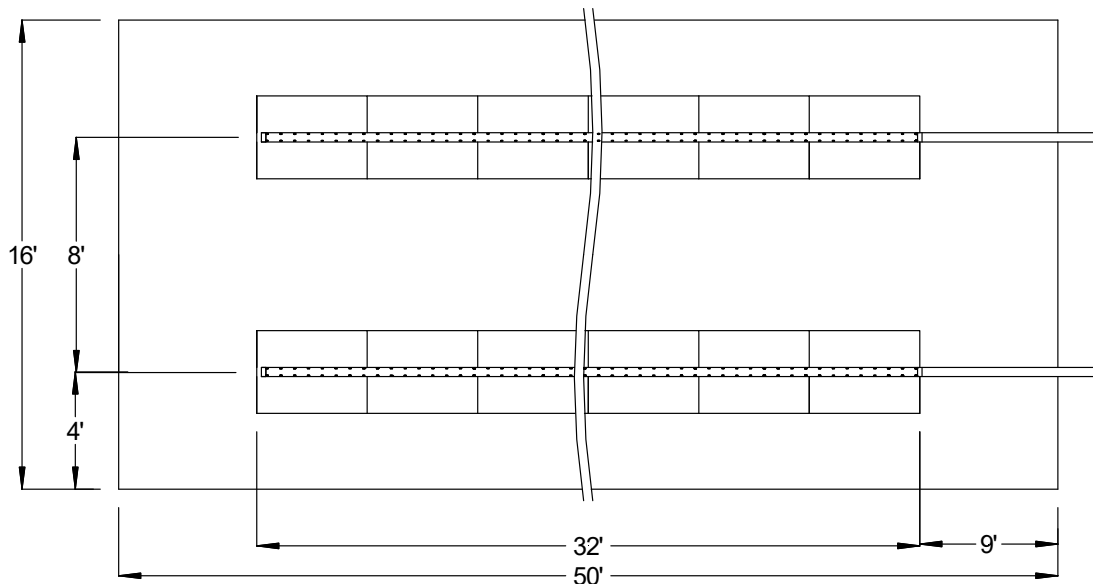
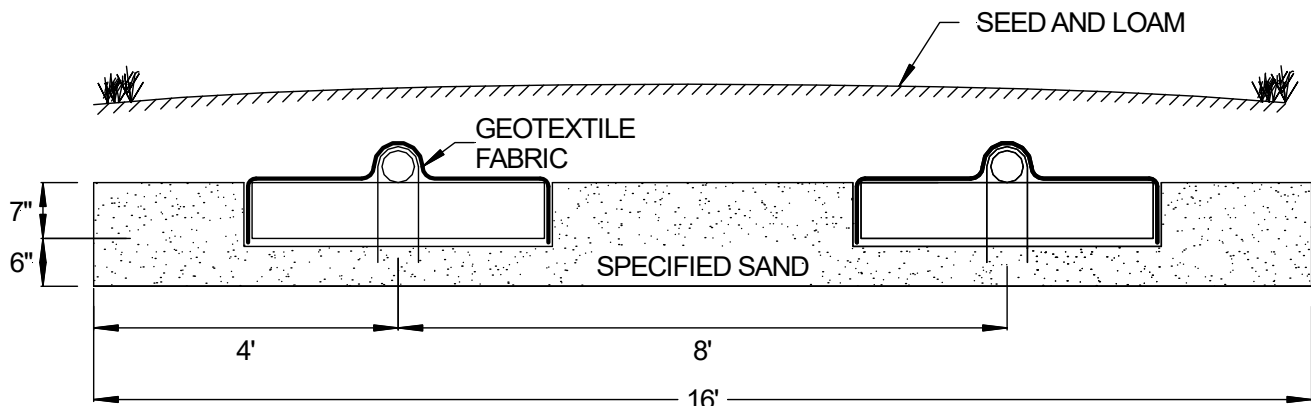

FIGURE 10: SECTION VIEW – BED SYSTEM EXAMPLE



4.0 Bed Installation Sizing and Guidelines

1. Ensure all components leading to the GSF system are installed properly. Septic tank effluent filters are required with the GSF system.
2. Determine the number of GSF Modules required using the bed sizing example.
3. Prepare the site. Do not install a system on saturated ground or wet soils that are smeared during excavation. Keep machinery off infiltrative areas.
4. Plan all drainage requirements above (up-slope) of the system. Set soil grades to ensure that storm water drainage and ground water is diverted away from the absorption area once the system is complete.
5. Excavate the bed absorption area; prepare the receiving layer to maximize the interface between the native soil and specified sand.
6. Minimize walking in the absorption area prior to placement of the specified sand to avoid soil compaction.
7. Place specified sand in 6" lifts, stabilize by foot, a hand held tamping tool or a portable vibrating compactor. The minimum stabilized height below the GSF module must be level at 6".
8. Place GSF modules with **PAINTED STRIPE FACING UP**, end to end on top of the specified sand along their 4-foot length.
9. A standard 4-inch perforated pipe, SDR 35 or equivalent, is centered along the modules 4-foot length. Orifices are set at the 4 & 8 o'clock position.
10. All 4-inch pipes are secured with manufacturers supplied wire clamps, one per module.
11. (Pressure Distribution Systems) Insert a pressure pipe (size per design and code) into the standard 4-inch perforated pipe. The pressure pipe orifices are set at the 12 o'clock position as shown in Figure 13. Each pressure lateral will have a drain hole at the 6 o'clock position. Each pressure lateral shall include sweeping cleanouts at the terminal ends and be accessible from grade.
12. **Cover fabric substitution is not allowed.** The installer should lay the Eljen provided geotextile cover fabric lengthwise down the row, with the fabric fitted to the perforated pipe on top of the GSF modules. Fabric should be neither too loose, nor too tight. The correct tension of the cover fabric is set by:
 - a. Spreading the cover fabric over the top of the module and down both sides of the module with the cover fabric tented over the top of the perforated distribution pipe.
 - b. Place shovelfuls of Specified Sand directly over the pipe area allowing the cover fabric to form a mostly vertical orientation along the sides of the pipe. Repeat this step moving down the pipe.
13. Place 12 inches of Specified Sand along both sides of the modules edge. A minimum of 12 inches of Specified Sand is placed at the beginning and end of each module row. Beds on level sites require a minimum spacing of 12" of Specified Sand between parallel module rows.
14. Complete backfill with a minimum of 12 inches of clean porous fill measured from the top of the pipe. Backfill exceeding 18 inches requires venting at the far end of the bed. Use well graded native soil fill that is clean, porous and devoid of large rocks. Do not use wheeled equipment over the system. A light track machine may be used with caution, avoiding crushing or shifting of pipe assembly.
15. Divert surface runoff from the system. Finish grade to prevent surface ponding. Topsoil and seed system area to protect from erosion.

5.0 Mound Installation Guidelines

5.1 INSTALLING ABOVE NATURAL SOIL GRADE: If the portions of the installation are installed above natural soil grade, follow the guidelines provided and the local regulations. Mound distribution can be either gravity feed or pressure dosed. Use a minimum of 12 inches of sand under the units for all installations in less than 6 inches of grade.

FIGURE 11: INSTALLING ABOVE NATURAL SOIL GRADE

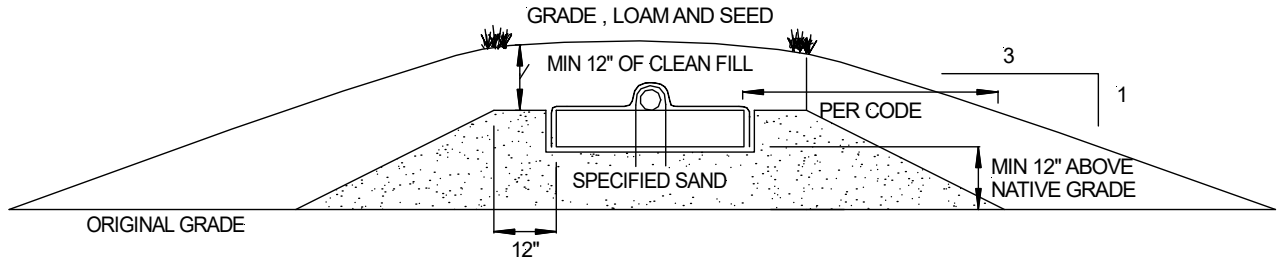

*Note: Design Can Utilize Either B43 or A42 Modules

FIGURE 12: CROSS SECTION – SLOPED MOUND SYSTEM

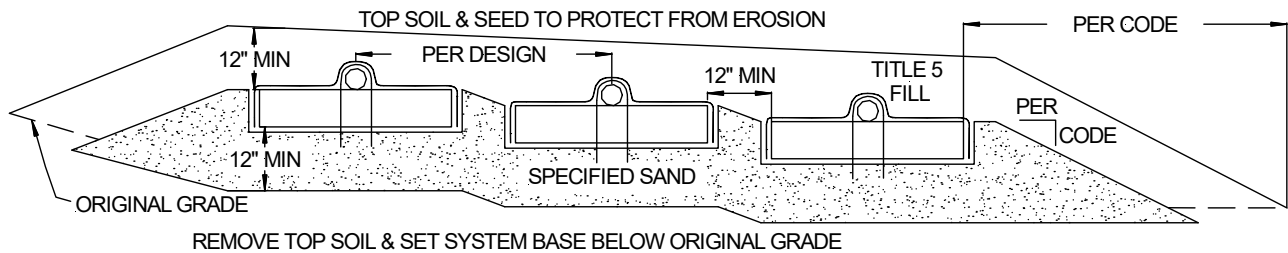

*Note: Design Can Utilize Either B43 or A42 Modules

5.0 Mound Installation Guidelines

1. Ensure all components leading to the GSF system are installed properly. Septic tank effluent filters are required with the GSF system.
2. Determine the number of GSF Modules required using the sizing formula.
3. Prepare the site. Do not install a system on saturated ground or wet soils that are smeared during preparation. Keep machinery off infiltrative areas.
4. Plan all drainage requirements above (up-slope) of the system. Set soil grades to ensure that storm water drainage and ground water is diverted away from the absorption area once the system is complete.
5. Remove the organic soil layer. Prepare the receiving layer to maximize the interface between the native soil and Specified Sand. Minimize walking in the absorption area prior to placement of the Specified Sand to avoid soil compaction.
6. Place fill material meeting local requirements (or Specified Sand requirements) onto the soil interface as you move down the excavated area. Place specified sand in a 6" lift, stabilize by foot, a hand held tamping tool or a portable vibrating compactor. The stabilized height below the GSF module must shall meet the mound design requirements.
7. Place GSF modules with **PAINTED STRIPE FACING UP**, end to end on top of the specified sand along their 4-foot length.
8. A standard perforated 4-inch distribution pipe is centered along the modules 4-inch length. Orifices are set at the 4 & 8 o'clock position.
9. All distribution pipes are secured with manufacturers supplied wire clamps, one per module.
10. (Pressure Distribution Systems) Insert a PVC Sch. 40 pressure pipe (size per design and code) into the standard perforated distribution pipe. The pressure pipe orifices are set at the 12 o'clock position as shown in Figure 13. Each pressure lateral will have a drain hole at the 6 o'clock position. Each pressure lateral shall include sweeping cleanouts at the terminal ends and be accessible from grade.
11. **Cover fabric substitution is not allowed.** The installer should lay the Eljen provided geotextile cover fabric lengthwise down the row, with the fabric fitted to the perforated pipe on top of the GSF modules. Fabric should be neither too loose, nor too tight. The correct tension of the cover fabric is set by:
 - a. Spreading the cover fabric over the top of the module and down both sides of the module with the cover fabric tented over the top of the perforated distribution pipe.
 - b. Place shovelfuls of Specified Sand directly over the pipe area allowing the cover fabric to form a mostly vertical orientation along the sides of the pipe. Repeat this step moving down the pipe.
12. Ensure there is 12 inches of specified sand surrounding the GSF modules in the mound. Slope the sand away from the mound as described on the plan.
13. Complete backfill with a minimum of 12 inches of cover material measured from the top of the module. Use well graded native soil fill that is clean, porous and devoid of large rocks. Do not use wheeled equipment over the system. A light track machine may be used with caution, avoiding crushing or shifting of pipe assembly. Divert surface runoff from the system. Finish grade to prevent surface ponding. Topsoil and seed system area to protect from erosion.
14. Divert surface runoff from the system. Finish grade to prevent surface ponding. Topsoil and seed system area to protect from erosion.

6.0 Dosing Distribution Guidance

6.1 PUMP TO DISTRIBUTION BOX: Specify an oversized distribution box for pumped dosed systems. Provide velocity reduction in the d-box with a tee or baffle. Set d-box outlets at the same elevation to equalize flow to each line or use drop boxes at the head of each line for serial distribution. If the absorption area is installed deeper than 18 inches, the system must be vented. See section 9.0 of this manual for detailed information on venting of systems.

6.2 DOSING DESIGN AND FLOW RATE: Dosing volume must be set to deliver a maximum of 4 gallons per B43 Module and 3 gallons per A42 Module per dosing cycle. Higher flow rates and short dose cycle push the effluent down the line and thus disperse the effluent over a larger area. A valve on the force main is recommended to set the flow rate so that the outlet pipes are submerged but prevents the d-box from over flowing.

For residential strength wastewater, the maximum B43 Module design flow shall not exceed 30 gallons per day per module; the maximum A42 Module design flow shall not exceed 25 gallons per day per module.

7.0 Pressure Distribution Guidance

7.1 TRENCHES EXCEEDING 500 LINEAL FEET: When more than 500 lineal feet of distribution line is required, a low-pressure dosed system shall be used in accordance with 20.7.3.701 NMAC, I.

7.1 PRESSURE DISTRIBUTION: Dosing with small diameter pressurized laterals is acceptable for GSF systems. The pipe networks must be engineered and follow principles established for pressure distribution. Flushing ports are required to maintain the free flow of effluent from orifices at the distal ends of each lateral. Contact Eljen's Technical Resource Department at 1-800-444-1359 for more information on pressure distribution systems

Standard procedures for design of pressure distribution networks apply to the GSF filter. Minimum orifice and lateral pipe size is based on design. A ¼ inch diameter drain hole is required at the beginning of each row at the 6 o'clock position of each pressure lateral for drainage purposes. The lateral pipe network is placed within a standard 4-inch perforated pipe. The perforation in the 4-inch outer pipe are set at the 5 and 7 o'clock position, the drilled orifices on the pressure pipe are set to spray at the 12 o'clock position directly to the top of the 4-inch perforated pipe as shown below.

FIGURE 13: PRESSURE PIPE PLACEMENT

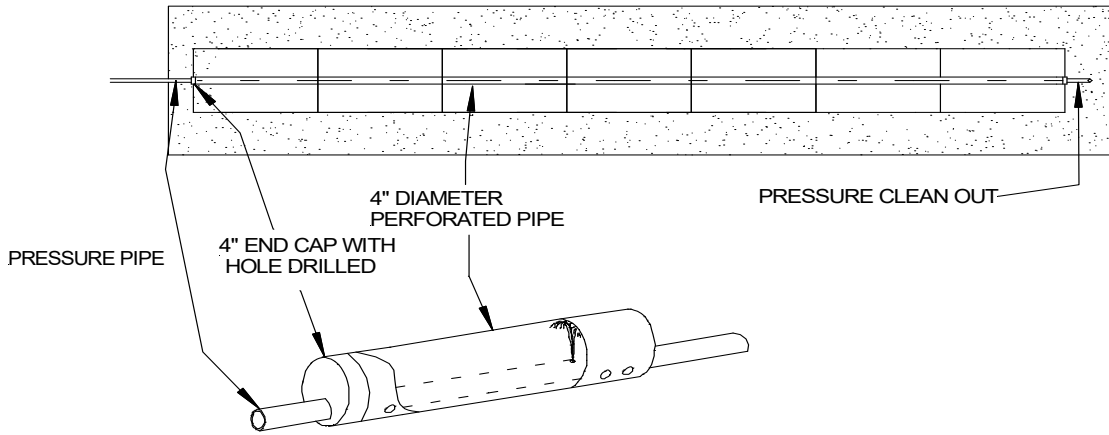

PRESSURE PIPE CROSS SECTION FOR ALL APPLICATIONS

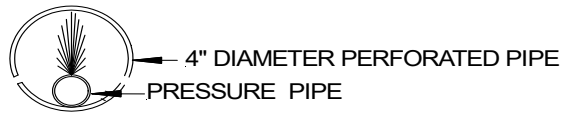
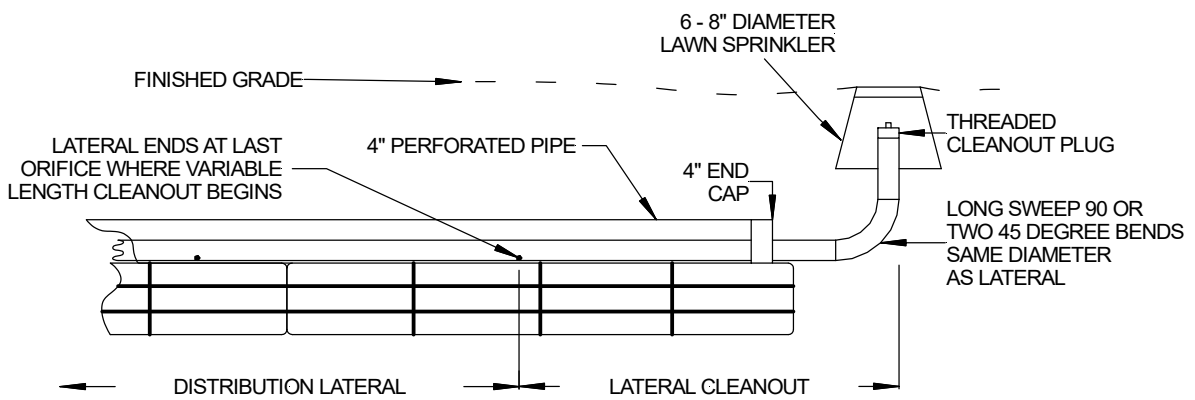
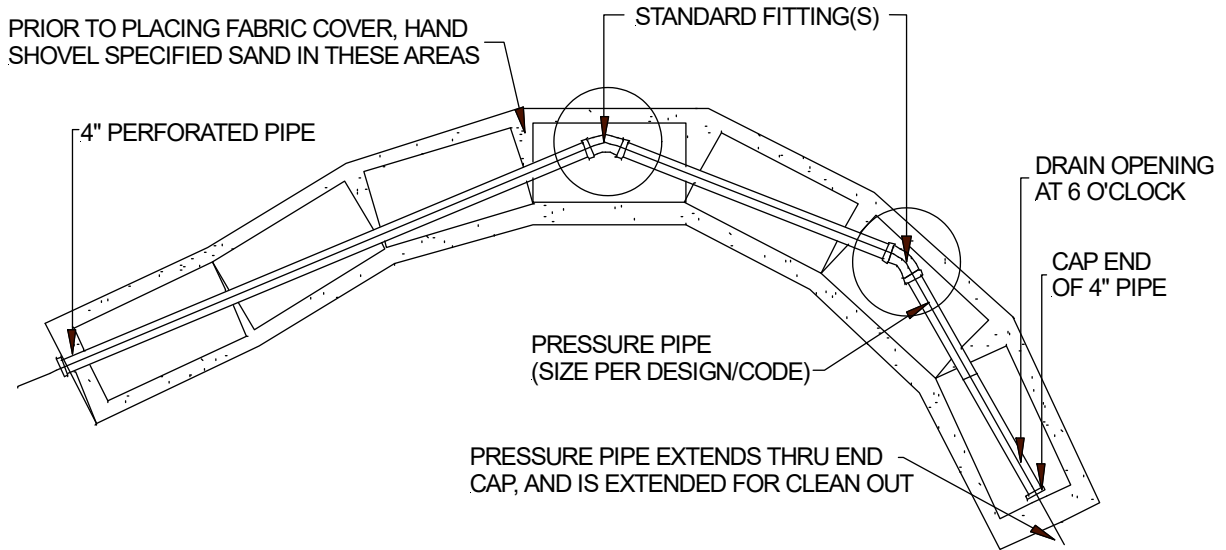

FIGURE 14: PRESSURE CLEAN OUT



7.0 Pressure Distribution Guidance

FIGURE 15: CONTOURED TRENCH PRESSURE DISTRIBUTION



GSF Pressure Distribution trench placed on a contour or winding trenches to maintain horizontal separation distances may also be used in Dosed or Gravity system by removing the pressure pipe and using the 4-inch diameter perforated distribution pipe.

8.0 Pump Controls

ELECTRICAL CONTROLS: Demand and Pressure Dosed controlled systems will include an electrical control system that has the alarm circuit independent of the pump circuit, controls, and components that are listed by UL or equivalent, is located outside, within line of sight of the pump chamber and is secure from tampering and resistant to weather (minimum of NEMA 4). The control panel shall be equipped with cycle counters and elapsed time meters. Where a water supply water meter is available it may be possible to eliminate the counters or timers.

The control panel shall be equipped with both audible and visual high liquid level alarms installed in a conspicuous location. Float switches shall be mounted independent of the pump and transport line so that they can be easily replaced and/or adjusted without removing the pump.

9.0 System Ventilation

9.1 SYSTEM VENTILATION: Air vents are required on all absorption systems located under impervious surfaces or systems **with more than 18 inches of cover material** as measured from the top of the GSF module to finished grade. This will ensure proper aeration of the modules and sand filter. The GSF has aeration channels between the rows of GSF modules connecting to cuspatations within the GSF modules. Under normal operating conditions, only a fraction of the filter is in use. The unused channels remain open for intermittent peak flows and the transfer of air.

9.2 VENT PIPE FOR GRAVITY AND LOW-PRESSURE SYSTEMS: Systems with over 18" of cover over the top of the modules require a vent. If the system is a low-pressure distribution system, ensure that the LPP clean outs are located in the vent for easy access.

FIGURE 16: VENT LAYOUTS FOR GRAVITY AND LOW-PRESSURE SYSTEMS

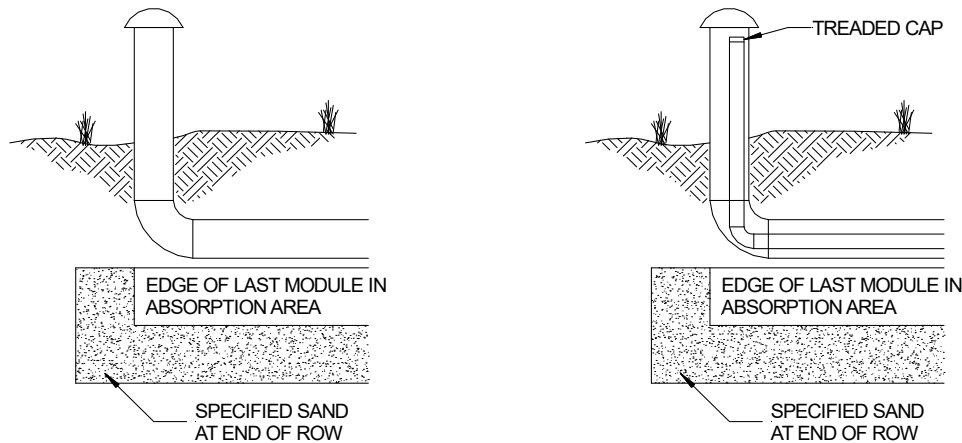

9.3 VENTILATION PLACEMENT: In a GSF system, the vent is usually a 4-inch diameter pipe extended to a convenient location behind shrubs, as shown in the figure below. Corrugated pipe may be used. If using corrugated pipe, ensure that the pipe does not have any bends that will allow condensation to pond in the pipe. This may close off the vent line. The pipe must have an invert higher than the system so that it does not drain effluent.

FIGURE 17: GSF WITH 4" VENT EXTENDED TO CONVENIENT LOCATION

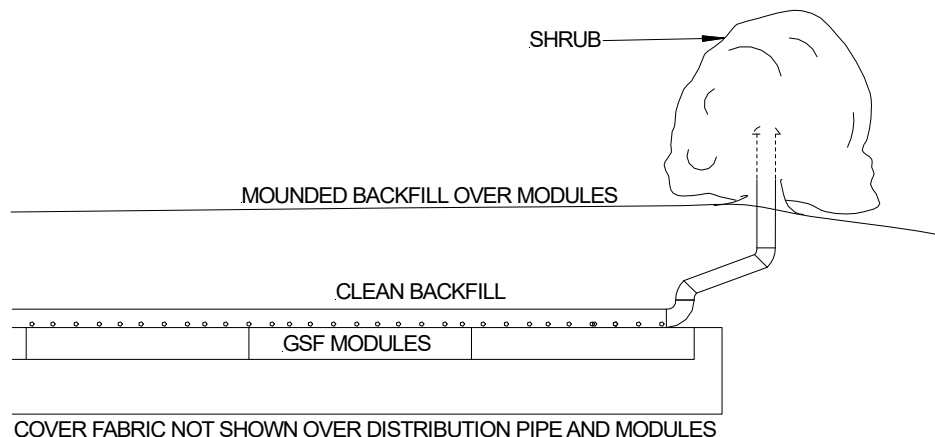

10.0 GSF Inspection Check List

Geotextile Sand Filter, (GSF) Checklist				
Facility Owner:				
Facility Address:				
Installation Date: (MDY)				
Previous Inspection Date: (MDY)				
Date of Inspection: (MDY)				
Residential Number of Bedrooms:				
Is this a Commercial Design? If yes what type:	Yes	No		
What is the estimated BOD5 and TSS strength?	BOD5	TSS	Comments	
Observation Port Location(s):	1	2	3	
Inspection Data, (complete all fields)				
Is daily flow within the system design flow? If no, explain:	Yes	No		
Does the owner verify the system use as described above? If no, explain:	Yes	No		
Septic tank last inspection date:	Date			
Inspected by:				
Septic tank last pumped date:				
Is pumping recommended?	Yes	No		
Condition of the soil absorption system: Wet, Dry, Firm, Soft, Vegetative, or Other. If Other, explain:	W	D	S	F V
Is there evidence of storm water flows or erosion over the septic system? If yes, explain:	Yes	No		

11.0 GSF Inspection Check List

Is there evidence of soil slump or compaction by traffic or other means in the vicinity of the soil absorption system? If yes, describe:	Yes	No	Comments
Is effluent visible through the observation port? If yes, describe the condition and the fluid level:	Yes	No	Comments
Is there a garbage disposal in the home?	Yes	No	Comments
Is a water softer connected to the system?	Yes	No	Comments
Are solids visible through the observation port? If yes, describe the condition and depth of solids:	Yes	No	Comments
Is there evidence of surcharging or effluent ponding in the D-Box? If yes, describe and measure:	Yes	No	Comments
Are the system vents in place?	Yes	No	Comments
Are they operational? If no, describe conditions and location:	Yes	No	
Describe any other pertinent issues:			

Inspected by:	
License Number:	
Date:	
Time:	
Print Name & Signature of Inspector:	
<p><i>I certify I have inspected the system at the above address, completed this report, and the information reported is true, accurate, and complete.</i></p>	

COMPANY HISTORY

Established in 1970, Eljen Corporation created the world's first prefabricated drainage system for foundation drainage and erosion control applications. In the mid-1980s, we introduced our Geotextile Sand Filter products for the passive advanced treatment of onsite wastewater in both residential and commercial applications. Today, Eljen is a global leader in providing innovative products and solutions for protecting our environment and public health.

COMPANY PHILOSOPHY

Eljen Corporation is committed to advancing the onsite industry through continuous development of innovative new products, delivering high quality products and services to our customers at the best price, and building lasting partnerships with our employees, suppliers, and customers.



125 McKee Street, East Hartford, CT 06108 • Tel: 800-444-1359 • Fax: 860-610-0427

www.eljen.com

