



Geotextile Sand Filter

Idaho

Design and Installation Manual



September 2018



125 McKee Street
East Hartford, CT 06108
Tel: 800-444-1359
Fax: 860-610-0427
www.eljen.com

Table of Contents

SUBJECT	PAGE
GLOSSARY OF TERMS.....	3
GSF SYSTEM DESCRIPTION	4
1.0 SYSTEM PRECONDITIONS	5
2.0 DESIGN AND INSTALLATION	6
3.0 TRENCH INSTALLATION SIZING AND GUIDELINES.....	10
4.0 BED INSTALLATION SIZING AND GUIDELINES	13
5.0 CAPPING FILL SYSTEM GUIDELINES	16
6.0 MOUND INSTALLATION SIZING AND GUIDELINES	17
7.0 DOSING DISTRIBUTION GUIDANCE	22
8.0 PRESSURE DISTRIBUTION GUIDANCE.....	22
9.0 SYSTEM VENTILATION.....	24
10.0 GSF INSPECTION CHECK LIST	26
GSF DRAWINGS AND TABLES	
DRAWINGS	
FIGURE 1: GSF SYSTEM OPERATION	4
FIGURE 2: TYPICAL A42 CROSS SECTION	6
FIGURE 3: SEQUENTIAL DISTRIBUTION DROP-BOX DETAIL.....	8
FIGURE 4: TRENCH CROSS SECTION.....	9
FIGURE 5: PLAN VIEW –TRENCH SYSTEM.....	11
FIGURE 6: SECTION VIEW – TRENCH SYSTEM – LEVEL SITE	11
FIGURE 7: SECTION VIEW – TRENCH SYSTEM – SLOPING SITE	11
FIGURE 8: PLAN VIEW – BED SYSTEM	14
FIGURE 9: SECTION VIEW – BED SYSTEM	14
FIGURE 10: TYPICAL A42 CROSS SECTION	16
FIGURE 11: TYPICAL A42 CROSS SECTION	16
FIGURE 12: CROSS SECTION – MOUND SYSTEM	17
FIGURE 13: PLAN VIEW – MOUND SYSTEM.....	17
FIGURE 14: PLAN VIEW – ELJEN BED CELL.....	20
FIGURE 15: PRESSURE PIPE PLACEMENT	22
FIGURE 16: PRESSURE CLEAN OUT	23
FIGURE 17: CONTOURED TRENCH PRESSURE DISTRIBUTION.....	23
FIGURE 18: VENT LAYOUTS FOR GRAVITY AND LOW-PRESSURE SYSTEMS.....	24
FIGURE 19: AIR BY-PASS LINE PLAN VIEW FOR VENTING OF PUMPED SYSTEMS.....	24
FIGURE 20: GSF WITH 4” VENT EXTENDED TO CONVENIENT LOCATION.....	25
TABLES	
TABLE 1: SPECIFIED SAND SIEVE REQUIREMENTS.....	3
TABLE 2: VERTICAL SEPARATION.....	6
TABLE 3: APPLICATION RATES.....	9
TABLE 4: SQUARE FOOTAGE PER A42 PER TRENCH APPLICATION	9

Glossary of Terms

A42 Module	48" x 24" x 7" (L x W x H)
Cover Fabric	The geotextile cover fabric (provided by manufacturer) that is placed over the GSF modules.
Design Flow	The estimated peak flow that is used to size a GSF system for a 3-bedroom single family dwelling or mobile home is 250 gallons per day +/- 50 gallons/Bedroom.
Flow Dial/Equalizer	Special insert placed in the end of distribution pipes within the distribution box to compensate for possible unlevel installation and promote favorable flow to the distribution pipes.
GSF	The Eljen Geotextile Sand Filter Modules and the 6-inch sand layer at the base and the 6-inch layer along the sides of the modules.
GSF Module	The individual module of a GSF system. The module is comprised of a cusped plastic core and geotextile fabric.
Specified Sand	To ensure proper system operation, the system MUST be installed with Medium Sand as specified in the Idaho Technical Guidance Manual, 3.2.8.1.2 Medium Sand. Sand must be used with not more than 10% passing the #100 Sieve and not more than 2% passing the # 200 sieve. Ask your material supplier for a sieve analysis to verify that your material meets the required specifications.

TABLE 1: SPECIFIED SAND SIEVE REQUIREMENTS

3.2.8.1.2 MEDIUM SAND SAND SPECIFICATION		
Sieve Size	Sieve Square Opening Size	Specification Percent Passing (Wet Sieve)
3/8 inch	9.52 mm	100
No. 4	4.76 mm	95 - 100
No. 8	2.38 mm	80 - 100
No. 16	1.19 mm	50 - 85
No. 30	590 µm	25 - 60
No. 50	297 µm	10 - 30
No. 100	149 µm	2 - 10
No. 200	75 µm	< 2

GSF System Description

Primary Treatment Zone

- Perforated pipe is centered above the GSF module to distribute septic effluent over and into corrugations created by the cusped core of the geotextile module.
- Septic effluent is filtered through the Bio-Matt fabric. The module's unique design provides increased surface area for biological treatment that greatly exceeds the module's footprint.
- Open air channels within the module support aerobic bacterial growth on the modules geotextile fabric interface, surpassing the surface area required for traditional absorption systems.
- An anti-siltation geotextile fabric covers the top and sides of the GSF module and protects the Specified Sand and soil from clogging, while maintaining effluent storage within the module.

Secondary Treatment Zone

- Effluent drips into the Specified Sand layer and supports unsaturated flow into the native soil. This Specified Sand/soil interface maintains soil structure, thereby maximizing the available absorption interface in the native soil. The Specified Sand supports nitrification of the effluent, which reduces oxygen demand in the soil, thus minimizing soil clogging from anaerobic bacteria.
- The Specified Sand layer also protects the soil from compaction and helps maintain cracks and crevices in the soil. This preserves the soil's natural infiltration capacity, which is especially important in finer textured soils, where these large channels are critical for long-term performance.
- Native soil provides final filtration and allows for groundwater recharge.

FIGURE 1: GSF SYSTEM OPERATION

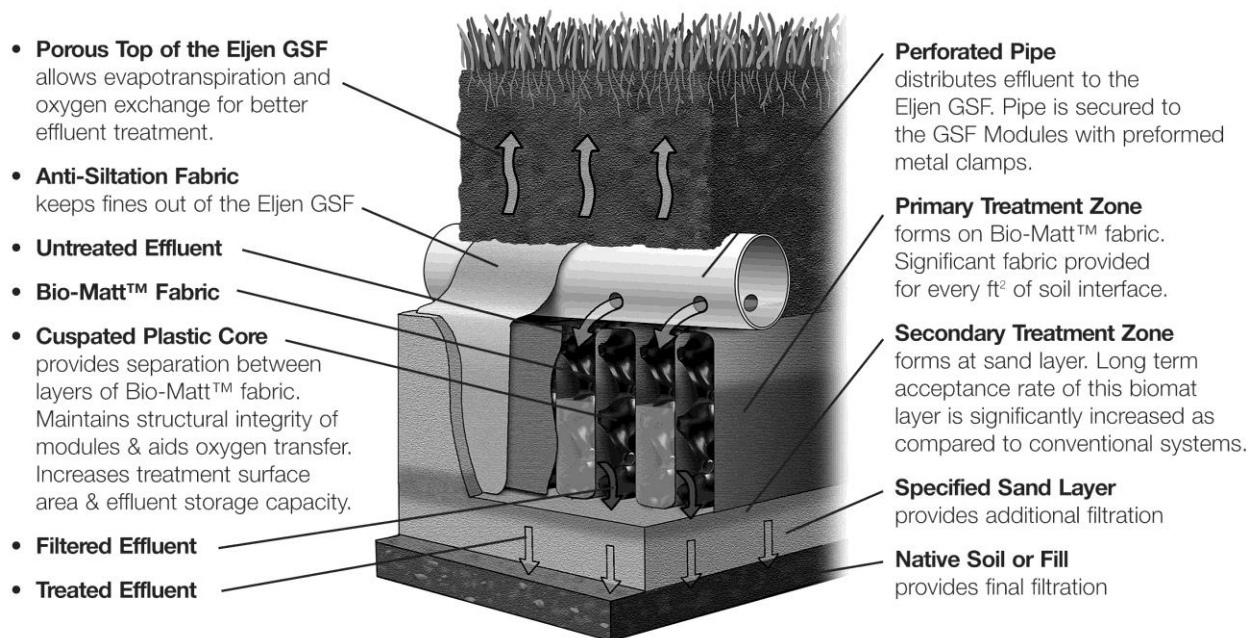

1.0 System Preconditions

1.1 REQUIREMENTS: GSF systems must meet the local rules and regulations except as outlined in this manual. The Idaho Regulations IDAPA.58.01.03.009.02 and the local regulations will be referred to as the *guidelines*.

Contact our technical department if a question arises to components and configurations not covered in this manual. Local approving authorities can request written consent regarding components and configurations from Eljen to ensure compliance.

The sizing charts apply to residential systems only and are found in section 2.16. Please contact Eljen's Technical Resource Department at 1-800-444-1359 for design information on commercial systems.

1.2 GARBAGE DISPOSALS: The use of a garbage disposal is not recommended as they can cause septic system problems by generating an increase of suspended solids, grease and nutrients.

However, if such units are proposed to be used, other measures should be taken to mitigate the increased nutrients to the field. Consult your local and state code for garbage disposal requirements. Eljen recommends a dual compartment tank or tanks in series. Consider upsizing the field for the additional biological load.

NOTE: Eljen requires the use of septic tank outlet effluent filters on all systems. Filters with higher filtration are recommended for systems with garbage disposals.

1.3 ADDITIONAL FACTORS AFFECTING RESIDENTIAL SYSTEM SIZE: Homes with expected higher than normal water usage may consider increasing the septic tank volume as well as incorporating a multiple compartment septic tank. Consideration for disposal area may be up-sized for expected higher than normal water use.

For example:

- Luxury homes, homes with a Jacuzzi style tubs, and other high use fixtures.
- Homes with known higher than normal occupancy.

1.4 SYSTEM PROHIBITED AREAS: All vehicular traffic is prohibited over the GSF system. GSF systems shall not be installed under paved or concreted areas. If the system is to be installed in livestock areas, the system must be fenced off around the perimeter to prevent compaction of the cover material and damage to the system.

1.5 ELJEN INSTALLER CERTIFICATION: All installers are required to be trained and certified by an authorized Eljen representative. Contact your local distributor for training information.

2.0 Design and Installation

FIGURE 2: TYPICAL A42 CROSS SECTION

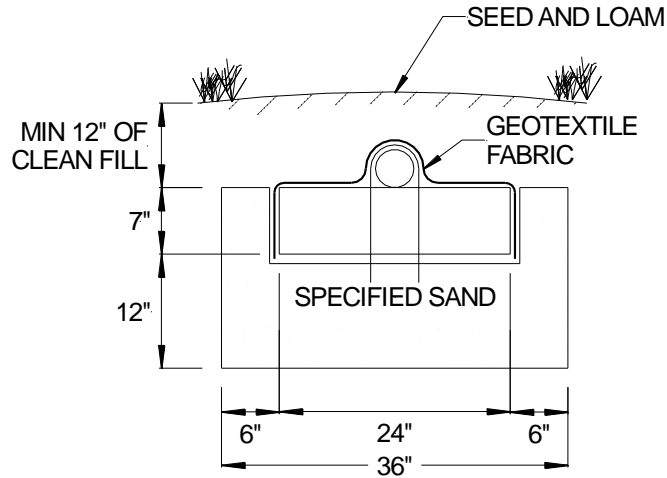

A42 MODULE (L x W x H) 48" x 24" x 7"

All systems are required to have a minimum of:

- 6 inches of Specified Sand is at the edges of the GSF module.
- 6 inches of Specified Sand is at the beginning and end of each GSF Row.
- 12 inches of Specified Sand is directly below the GSF module.
- Minimum 12 inches of cover above the module.

2.0 Design and Installation

2.1 SEPTIC TANK: Septic tanks should be fitted with an effluent filter and sized according to state regulations. Many designers are now specifying dual compartment tanks for all their systems. Eljen supports this practice as it helps to promote long system life by reducing TSS and BOD to the effluent disposal area. Gas baffles and/or effluent filters are also recommended. Tanks shall meet the requirements of TGM Section 5.2

2.2 SEPTIC TANK FILTERS: Septic tank effluent filters are **REQUIRED** on the outlet end of septic tank. Filter manufactures require that filters be cleaned from time to time. Ask your installer or designer for specific cleaning requirements based on the type or make of the filter installed. Eljen requires the septic tank to be pumped every three years or as needed which would be a good time to check and conduct filter maintenance. Refer to section 5.9 of the Idaho Technical Guidance Manual for approved Septic Tank Effluent Filters.

2.3 VERTICAL SEPARATION TO LIMITING LAYER:

TABLE 2: VERTICAL SEPARATION

Idaho TGM Table 4.19 Recirculating gravel filter vertical separation to limiting layers (feet). Limiting Layer	Flow < 2,500 GPD All Soil Types	Flow ≥ 2,500 GPD All Soil Types
Impermeable layer	2	4
Fractured rock or very porous layer	1	2
Normal high ground water	1	2
Seasonal high ground water	1	2

2.0 Design and Installation

2.4 SPECIFIED SAND SPECIFICATION FOR GSF SYSTEMS: The sand immediately under, between rows and around the perimeter of the GSF system must meet 3.2.8.1.2 Medium Sand of the Idaho Technical Guidance Manual, **WITH 2-10% PASSING A #100 SIEVE AND LESS THAN 2% PASSING A #200 SIEVE.** Please place a prominent note to this effect on each design drawing. See Table 1 for more information on the sand and sieve specifications.

2.5 PLACING GSF MODULES: The “painted stripe” on the GSF modules indicates the top of the module and is not intended to indicate the location of the distribution pipe. With the painted stripe facing up, all rows of GSF modules are set level, end to end on the Specified Sand layer.

2.6 DISTRIBUTION: Gravity, pump to gravity or pressure distribution are acceptable when using the GSF System. Piping shall meet the requirements guidelines; however, Eljen strongly recommends the use of SDR 35 pipe and fittings as to prevent crushing during backfill. All distribution piping must meet a minimum 2,500-pound crush test specification for polyvinyl chloride (PVC) drain, waste and vent pipe.

All systems require a perforated 4” diameter pipe centered on top of the GSF modules unless the system is curving. The distribution pipe continues along the entire length of all modules in a trench or row. Holes are set at the 4 and 8 o’clock position and secured by the Eljen provided wire clamps.

When using pressure distribution, a pressure manifold is placed inside the 4-inch distribution pipe. Section 8.0 of this manual goes into details of how to construct the distribution network. All piping must meet state and local regulations.

2.7 CONNECTIONS AND FITTINGS: Connections of lines to tanks and distribution boxes must be made using watertight seals. Use of any grouting material is not permitted.

2.8 DISTRIBUTION BOX: Set the gravity system D-box outlet invert a minimum of 1/8 inch drop in elevation per linear foot to the top first module in the row. Set a 2-inch minimum drop for dosed systems from the D-box to the modules. Ensure that the distribution box and pipes feeding the system are placed on compacted soil. Flow Dials may be used in either Gravity or Dosed installations.

2.9 INSTALLING ON SLOPING TERRAIN: For trench systems, edge-to-edge trench spacing will be a minimum of 6 feet. For bed systems, edge-to-edge minimum spacing will be 1 foot (lateral to lateral of 3 feet).

Provide a D-box at the beginning of the first row of modules for effluent distribution and velocity reduction and as a system inspection port. Lower rows may also be loaded from one or more D-boxes with Flow Dials to insure effluent is distributed per design requirements. Serial or equal distribution is permitted.

Equal Distribution: Set Flow Dials to insure effluent is distributed equally to all rows in the system.

Serial Distribution: Set Flow Dials to insure effluent is loaded to the upslope trench first before continuing to lower trenches within the system.

2.10 EQUAL DISTRIBUTION: Parallel distribution is the preferred method of dosing to a gravity or pump to gravity system. It encourages equal flows to each of the lines in the system. It is recommended for most trench systems.

2.11 SEQUENTIAL DISTRIBUTION: Sequential Distribution using a distribution box will fully utilize the uppermost section of the system prior to spilling effluent into a lower row of modules. This is for use on any site with greater than 0.5% slope when not using parallel distribution.

2.0 Design and Installation

FIGURE 3: SEQUENTIAL DISTRIBUTION DROP-BOX DETAIL

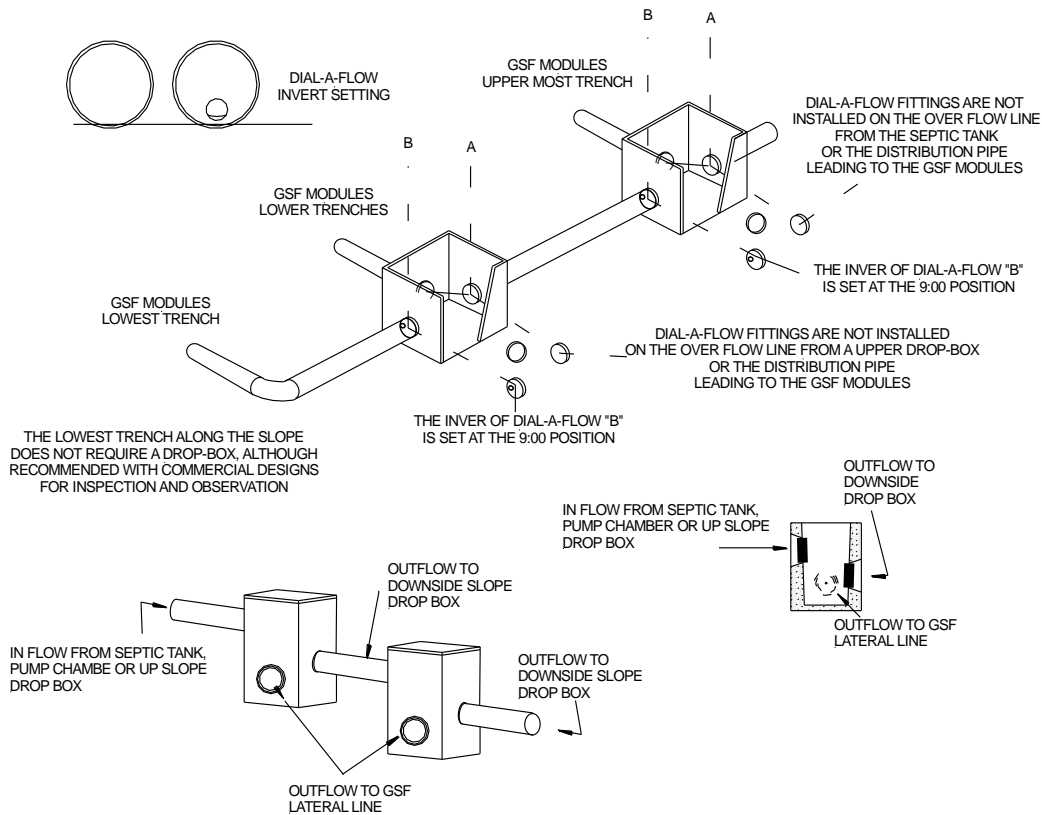

2.12 COVER FABRIC: Geotextile cover fabric is provided by Eljen Corporation for all GSF systems. It is placed over the top and sides of the module rows to prevent long term siltation and failure. **Cover fabric substitution is not allowed.** Fabric should drape vertically over the pipe and must not block holes in the distribution pipe or be stretched from the top of the pipe to the outside edge of the modules. "Tenting" will cause undue stress on fabric and pipe.

2.13 SYSTEM VENTING: It is required to vent all systems that are over 18" below finished grade and systems beneath any surface condition that would not allow for surface air exchange with the system such as patios. See Section 9.0 for a more detailed explanation of venting GSF products.

2.14 BACKFILL & FINISH GRADING: Complete backfill with a minimum of 12 inches of clean porous fill measured from the top of modules. Use well graded sandy fill that is clean, porous and devoid of large rocks. Do not use wheeled equipment over the system. A light track machine may be used with caution, avoiding crushing or shifting of pipe assembly. Divert surface runoff from the system absorption area. Finish grade to prevent surface ponding. Seed and loam system area to protect from erosion.

2.15 SYSTEM GEOMETRY: Design systems as long and narrow as practical along site contours to minimize ground water mounding especially in poorly drained low permeability soils. If possible, design level systems with equal number of modules per row.

There is a minimum 6-foot separation between trenches, measured from sidewall to sidewall.

In bed systems, it is acceptable to space the units to maximize points of application to the basal area. Laterals shall be no greater than 6 feet on centers and no greater than 4 feet from the sidewalls.

2.16 NUMBER OF GSF MODULES REQUIRED: Residential systems use a minimum of six (6) modules per bedroom. See Section 2.17 for more information on systems sizing.

2.0 Design and Installation

2.17 SYSTEM SIZING: When determining the correct sizing for your GSF system, it is important to follow your local codes and regulations for proper surface and subsurface classifications.

TABLE 3: APPLICATION RATES

Soil Group	Soil subgroup	Soil Texture Classification	USDA Field Test Textural Classification	Application Rate	Minimum Units Per Bedroom (Bed Applications Only)
A	A1	Medium Sand	30-60 Mesh	1.7	6
	A2a	Medium Sand	Poorly Graded	1.2	
	A2b	Fine Sand	Sand 60-140 Mesh	1.0	
		Loamy Sand	Sand		
B	B1	Very Fine Sand	Sand 140-270 Mesh	0.8	9
		Sandy Loam	Sandy Loam		
		Very Fine Sandy Loam	Sandy Loam		
	B2	Loam	–	0.6	
		Silt Loam	Silt Loam		
		Sandy Clay Loam	(≤27% Clay)		
C	C1	Silt	Silt Loam	0.4	12
		Sandy Clay Loam	Clay Loam (≥27% Clay)		
		Silty Clay Loam	Clay Loam		
	C2	Clay Loam	Clay Loam	0.3	

1. Per IDAPA 58.01.03.008.04, the bottom of the System Sand excavation must be installed level.
2. Systems with percolation rates in excess of 120 MPI are not allowed.
3. Drainfields larger than 1,500 ft² trench area bottom are prohibited from being constructed as standard (gravity)
4. Per IDAPA 58.01.03.008.04, a "Trench" is up to 6' wide, anything wider is considered a bed.
5. Maximum site slope per IDAPA 58.01.03 rules.

2.18 TRENCH SQUARE FOOTAGE BY TRENCH WIDTH:

TABLE 4: SQUARE FOOTAGE PER A42 PER TRENCH APPLICATION

TRENCH WIDTH	SAND EXTENSION	SQUARE FOOT PER MODULE
3 FOOT	6 INCHES	12
4 FOOT	12 INCHES	16
5 FOOT	18 INCHES	20
6 FOOT	24 INCHES	24

FIGURE 4: TRENCH CROSS SECTION

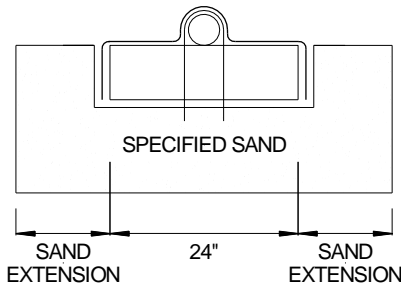

3.0 Trench Installation Sizing and Guidelines

Trench Example:

House size: 3 Bedrooms
 Design Flow: 250 gpd
 Soil Type: Soil B2; Silt Loam (0.6 gpd/sf)
 Absorption Field Type: Trench

Calculate Minimum Absorption Area

Lookup loading rate from Table 3 and determine the loading rate:

Soil Group	Soil subgroup	Soil Texture Classification	USDA Field Test Textural Classification	Application Rate	Minimum Units Per Bedroom (Bed Applications Only)
B	B1	Very Fine Sand	Sand 140-270 Mesh	0.8	9
		Sandy Loam	Sandy Loam		
		Very Fine Sandy Loam	Sandy Loam		
	B2	Loam	-	0.6	
		Silt Loam	Silt Loam		
		Sandy Clay Loam	(≤27% Clay)		

Absorption Area: Design Flow ÷ Loading Rate

$250 \text{ gpd} \div 0.6 \text{ gpd} / \text{ft}^2 = 416.66 \text{ ft}^2$

Calculate Number of Modules Required

TRENCH WIDTH	SAND EXTENSION	SQUARE FOOT PER MODULE
3 FOOT	6 INCHES	12
4 FOOT	12 INCHES	16
5 FOOT	18 INCHES	20
6 FOOT	24 INCHES	24

Number of units required = Absorption Area ÷ Square Foot Per Module

Units required

$417 \text{ ft}^2 \div 12 \text{ ft}^2 / \text{module} = 34.7 \text{ Modules}$
 Round to: 35 Modules

Calculate Minimum Trench Length

$35 \text{ Units} \times 4 + 1 = 141 \text{ linear feet}$

Trench Width

Trench width = unit width + sand extension
 $36 = 24" + 12"$ (6" sand both sides of unit) 3 ft.

Final Dimension Layout

(Note: System layout and number of rows will vary based on site constraints)

Min. Product Length	140 ft.
(note: 6 inches of sand required at each end of trench which makes the minimum trench length 141 ft.)	
Trench Width	3 ft.
Minimum Number of Units	35 Modules
2 Trench Rows	18 Modules each row, 73 ft. per row.
Min. System Area	420 ft ²

3.0 Trench Installation Sizing and Guidelines

FIGURE 5: PLAN VIEW – TRENCH SYSTEM

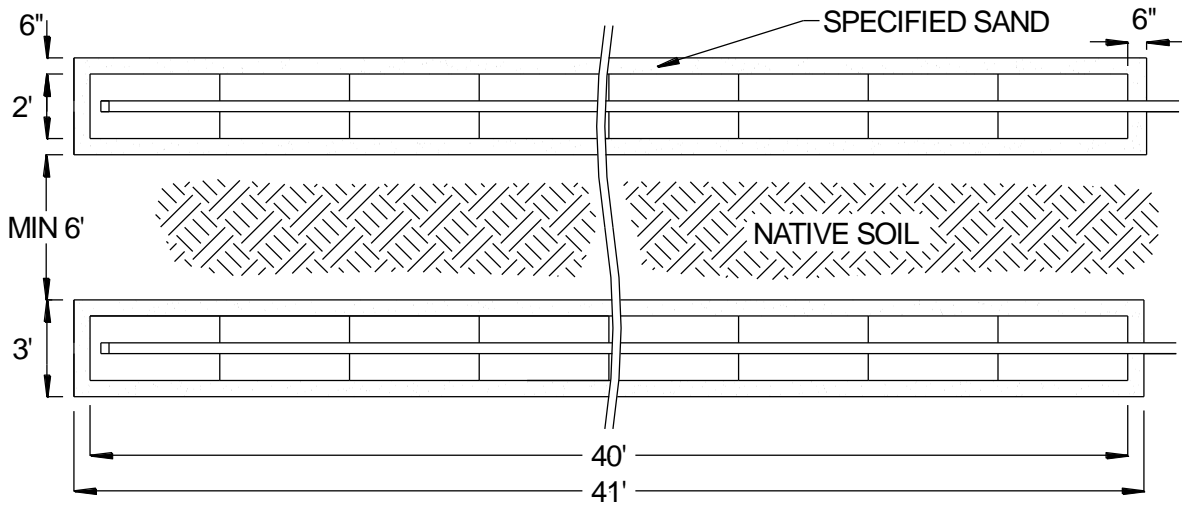

FIGURE 6: SECTION VIEW – TRENCH SYSTEM – LEVEL SITE

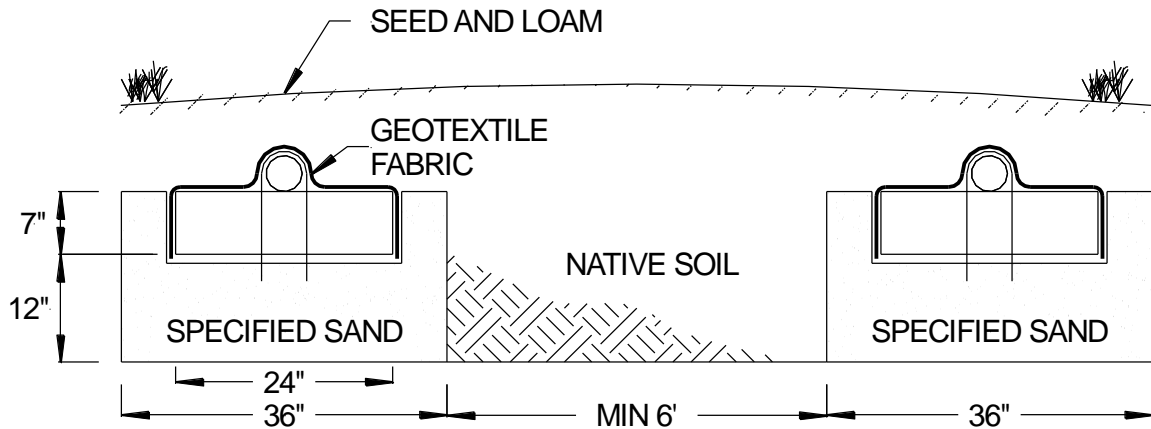
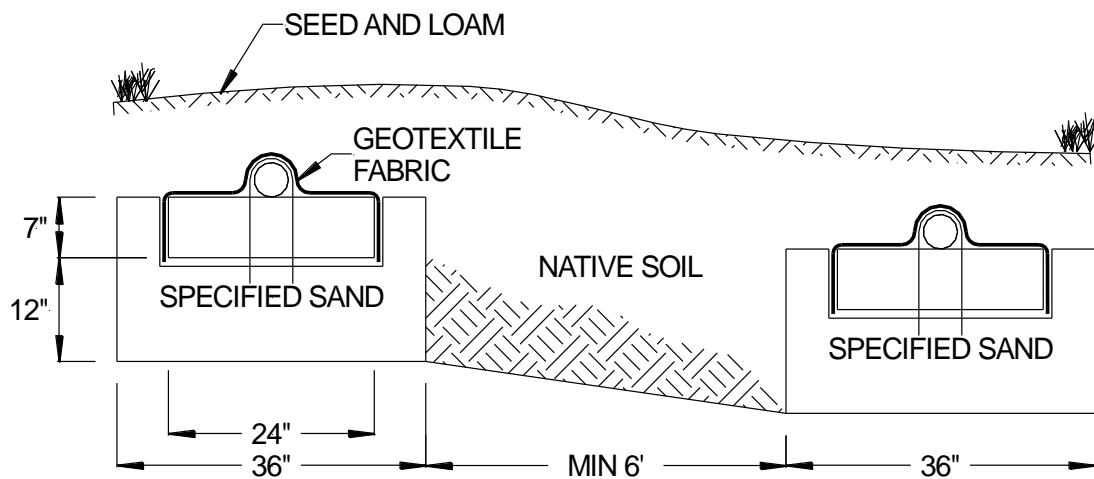

FIGURE 7: SECTION VIEW – TRENCH SYSTEM – SLOPING SITE



3.0 Trench Installation Sizing and Guidelines

1. Ensure all components leading to the GSF system are installed properly. Septic tank effluent filters are required with the GSF system.
2. Determine the number of GSF Modules required using the trench sizing example.
3. Prepare the site. Do not install a system on saturated ground or wet soils that are smeared during excavation. Keep machinery off infiltrative areas.
4. Plan all drainage requirements above (up-slope) of the system. Set soil grades to ensure that storm water drainage and ground water is diverted away from the absorption area once the system is complete.
5. Excavate the trench; scarify and prepare the receiving layer to maximize the interface between the native soil and specified sand.
6. Minimize walking in the trench prior to placement of the specified sand to avoid soil compaction.
7. Place specified sand in a 6" lift and stabilize by foot, a hand held tamping tool or a portable vibrating compactor. The minimum stabilized height below the GSF module must be level at 12".
8. Place GSF modules with **PAINTED STRIPE FACING UP**, end to end on top of the specified sand along their 4-foot length.
9. A standard 4-inch perforated pipe, SDR 35 or equivalent, is centered along the modules 4-foot length. Orifices are set at the 4 & 8 o'clock position.
10. All 4-inch pipes are secured with manufacturers supplied wire clamps, one per module.
11. (Pressure Distribution Systems) Insert a pressure pipe (size per design and code) into the standard 4-inch perforated pipe. The pressure pipe orifices are set at the 12 o'clock position as shown in Figure 15. Each pressure lateral will have a drain hole at the 6 o'clock position. Each pressure lateral shall include sweeping cleanouts at the terminal ends and be accessible from grade. The distribution pipe is capped at both ends with a hole cut throw to allow the pressure pipe through.
12. **Cover fabric substitution is not allowed.** The installer should lay the Eljen provided geotextile cover fabric lengthwise down the trench, with the fabric fitted to the perforated pipe on top of the GSF modules. Fabric should be neither too loose, nor too tight. The correct tension of the cover fabric is set by:
 - a. Spreading the cover fabric over the top of the module and down both sides of the module with the cover fabric tented over the top of the perforated distribution pipe.
 - b. Place shovelfuls of Specified Sand directly over the pipe area allowing the cover fabric to form a mostly vertical orientation along the sides of the pipe. Repeat this step moving down the pipe.
13. Place the sand extensions along both sides of the modules edge. A minimum of 6 inches of Specified Sand is placed at the beginning and end of each trench.
14. Complete backfill with a minimum of 12 inches of clean porous fill measured from the top of the module. Backfill exceeding 18 inches requires venting at the far end of the trench. Use well graded native soil fill that is clean, porous and devoid of large rocks. Do not use wheeled equipment over the system. A light track machine may be used with caution, avoiding crushing or shifting of pipe assembly.
15. Divert surface runoff from the system. Finish grade to prevent surface ponding. Topsoil and seed system area to protect from erosion.

4.0 Bed Installation Sizing and Guidelines

Bed Example:

House size: 3 Bedrooms
 Design Flow: 250 gpd
 Soil Type: Silt Loam (0.6 gpd/sf)
 Absorption Field Type: Bed

Calculate Minimum Absorption Area

Lookup loading rate from Table 3:

Soil Group	Soil subgroup	Soil Texture Classification	USDA Field Test Textural Classification	Application Rate	Minimum Units Per Bedroom (Bed Applications Only)
B	B1	Very Fine Sand	Sand 140-270 Mesh	0.8	9
		Sandy Loam	Sandy Loam		
		Very Fine Sandy Loam	Sandy Loam		
	B2	Loam	–	0.6	
		Silt Loam	Silt Loam		
		Sandy Clay Loam	(≤27% Clay)		

Absorption Area: Design Flow ÷ Loading Rate

$$250 \text{ gpd} \div 0.6 \text{ gpd} = 416 \text{ ft}^2$$

Calculate Number of Modules Required

Lookup units required per bedroom from Table 3:

Soil Group	Soil subgroup	Soil Texture Classification	USDA Field Test Textural Classification	Application Rate	Minimum Units Per Bedroom (Bed Applications Only)
B	B1	Very Fine Sand	Sand 140-270 Mesh	0.8	9
		Sandy Loam	Sandy Loam		
		Very Fine Sandy Loam	Sandy Loam		
	B2	Loam	–	0.6	
		Silt Loam	Silt Loam		
		Sandy Clay Loam	(≤27% Clay)		

Units Required: Number of Bedrooms x Units Required per Bedroom

$$3 \times 9 = 27 \text{ Units}$$

Calculate Minimum Bed Length

Maintain a minimum of 2 rows in a bed system. (2 Rows for this example)

$$27 \text{ Units} \div 2 \text{ Rows} = 13.5 \text{ Mods/Row}$$

$$\text{Round up} \quad 14 \text{ Mods/Row}$$

Calculate Minimum Row Length

$$14 \text{ Units} \times 4 \text{ ft./unit} = 56 \text{ ft.} + 6" \text{ sand each end} = 57 \text{ ft. per Row}$$

Bed Width

$$\text{Bed Width} = \text{Absorption Area} \div \text{Bed Length}$$

2 Rows

$$416 \text{ ft}^2 \div 57 \text{ ft.} = 7.29 \text{ ft.}, \text{ round to } 8 \text{ ft.}$$

Determine Lateral Spacing

$$\text{Lateral to Lateral Spacing} = \text{Bed Width} \div \text{Number of Rows}$$

2 Rows

$$8 \text{ ft.} \div 2 \text{ rows} = 4 \text{ ft.}$$

$$\text{Lateral to Edge Spacing} = \text{Lateral to Lateral Spacing} \div 2$$

$$4 \text{ ft.} \div 2 = 2 \text{ ft.}$$

4.0 Bed Installation Sizing and Guidelines

Final Dimension Layout

(Note: System layout and number of rows will vary based on site constraints)

Bed Length	57 ft.
Bed Width	8 ft.
Minimum Number of Units	28 Units
Units per Row	14 units per row
Lateral to Lateral Spacing	4 ft.
Lateral to Edge Spacing	2 ft.
System Area	456 ft ²

FIGURE 8: PLAN VIEW – BED SYSTEM

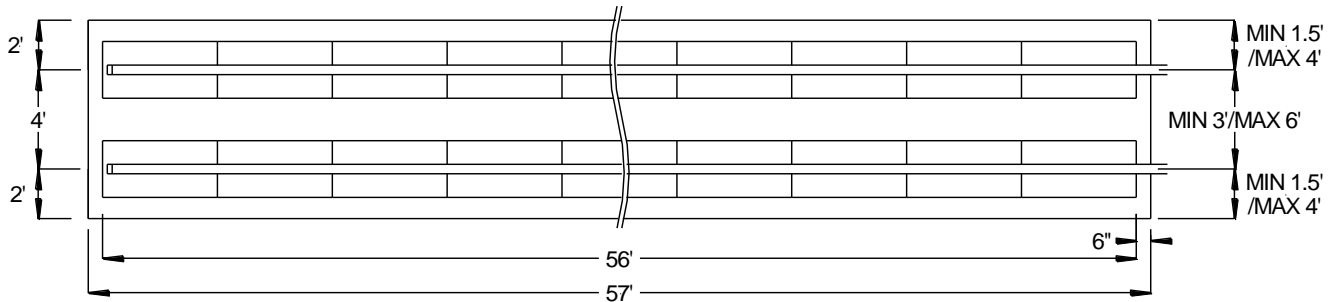
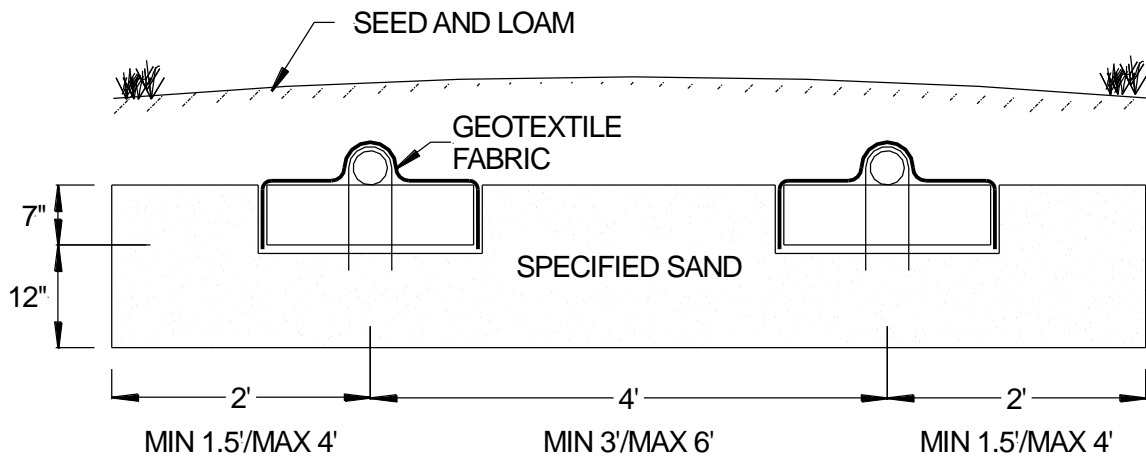

FIGURE 9: SECTION VIEW – BED SYSTEM



4.0 Bed Installation Sizing and Guidelines

1. Ensure all components leading to the GSF system are installed properly. Septic tank effluent filters are required with the GSF system.
2. Determine the number of GSF Modules required using the bed sizing example.
3. Prepare the site. Do not install a system on saturated ground or wet soils that are smeared during excavation. Keep machinery off infiltrative areas.
4. Plan all drainage requirements above (up-slope) of the system. Set soil grades to ensure that storm water drainage and ground water is diverted away from the absorption area once the system is complete.
5. Excavate the bed absorption area; scarify the receiving layer to maximize the interface between the native soil and specified sand.
6. Minimize walking in the absorption area prior to placement of the specified sand to avoid soil compaction.
7. Place specified sand in 2, 6" lifts, stabilize by foot, a hand held tamping tool or a portable vibrating compactor. The minimum stabilized height below the GSF module must be level at 12".
8. Place GSF modules with **PAINTED STRIPE FACING UP**, end to end on top of the specified sand along their 4-foot length.
9. A standard 4-inch perforated pipe, SDR 35 or equivalent, is centered along the modules 4-foot length. Orifices are set at the 4 & 8 o'clock position.
10. All 4-inch pipes are secured with manufacturers supplied wire clamps, one per module.
11. (Pressure Distribution Systems) Insert a pressure pipe (size per design and code) into the standard 4-inch perforated pipe. The pressure pipe orifices are set at the 12 o'clock position as shown in Figure 15. Each pressure lateral will have a drain hole at the 6 o'clock position. Each pressure lateral shall include sweeping cleanouts at the terminal ends and be accessible from grade.
12. **Cover fabric substitution is not allowed.** The installer should lay the Eljen provided geotextile cover fabric lengthwise down the row, with the fabric fitted to the perforated pipe on top of the GSF modules. Fabric should be neither too loose, nor too tight. The correct tension of the cover fabric is set by:
 - a. Spreading the cover fabric over the top of the module and down both sides of the module with the cover fabric tented over the top of the perforated distribution pipe.
 - b. Place shovelfuls of Specified Sand directly over the pipe area allowing the cover fabric to form a mostly vertical orientation along the sides of the pipe. Repeat this step moving down the pipe.
13. Place 6 inches of Specified Sand along both sides of the modules edge. A minimum of 6 inches of Specified Sand is placed at the beginning and end of each module row. A minimum of 12 inches of Specified Sand is placed in between module rows.
14. Complete backfill with a minimum of 12 inches of clean porous fill measured from the top of the module. Backfill exceeding 18 inches requires venting at the far end of the bed. Use well graded native soil fill that is clean, porous and devoid of large rocks. Do not use wheeled equipment over the system. A light track machine may be used with caution, avoiding crushing or shifting of pipe assembly.
15. Divert surface runoff from the system. Finish grade to prevent surface ponding. Topsoil and seed system area to protect from erosion.

5.0 Capping Fill System Guidelines

5.1 DESIGN: Use the calculations in Sections 3.0 or 4.0 to design your systems treatment and dispersal area. Place the bottom of the excavation for your design in accordance with the sites limiting conditions.

5.2 BELOW-GRADE CAPPING FILL SYSTEM: Follow the guidance located in TGM 4.3.2. The installation depth is between 12 and 24 inches below the natural soil and on no greater slope than 20%.

FIGURE 10: TYPICAL A42 CROSS SECTION

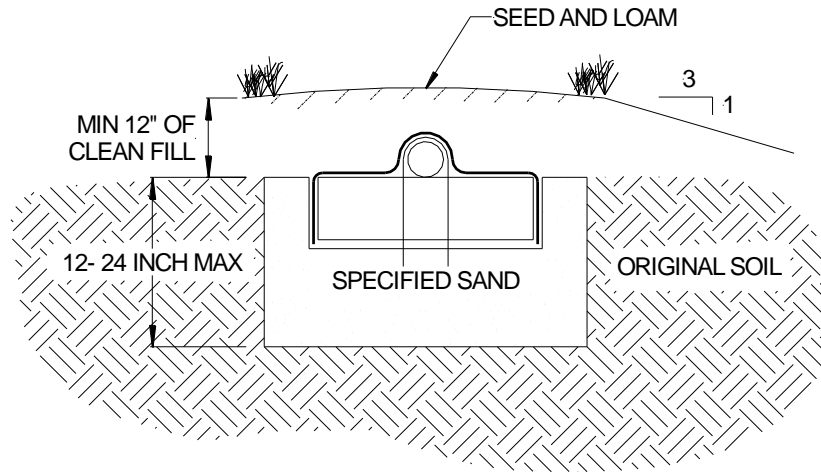

5.3 ABOVE-GRADE CAPPING FILL SYSTEM: Follow the guidance located in TGM 4.3.3. The installation depth is between 3 and 12 inches below the natural soil and on no greater slope than 12%. Minimum cover over the drainfield is 18 inches.

FIGURE 11: TYPICAL A42 CROSS SECTION

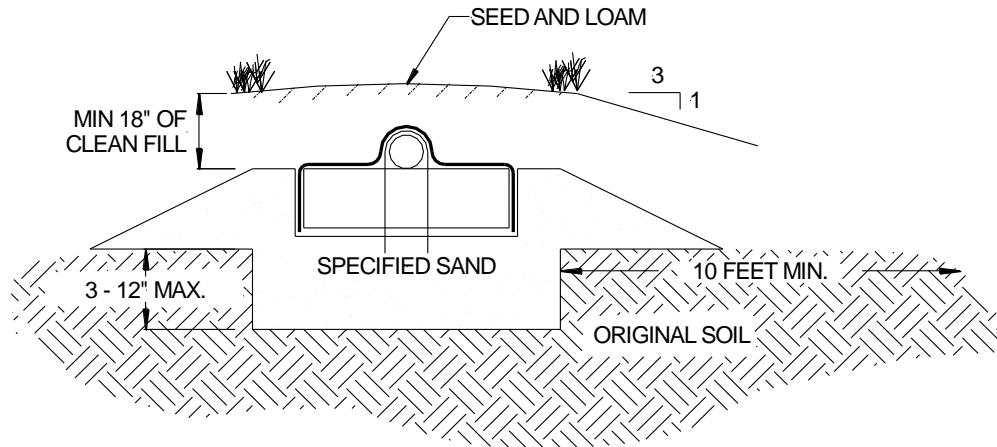

6.0 Mound Installation Sizing and Guidelines

6.1 MOUND REFERENCE: The following sizing and guidelines provide the dimensions of the dispersal bed for your mound. Consult the local regulations for more information on the construction of the mound system.

6.2 MOUND EXAMPLE:

House size:	3 bedrooms
Slope of site:	4%
Daily Design Flow: 250 gpd x 1.5 safety factor =	375 gpd
Nature of Limiting Condition:	High water table at 18 inches
Soil Application Rate (SAR) from Table 3:	0.6 gpd/ft ²

FIGURE 12: CROSS SECTION – MOUND SYSTEM

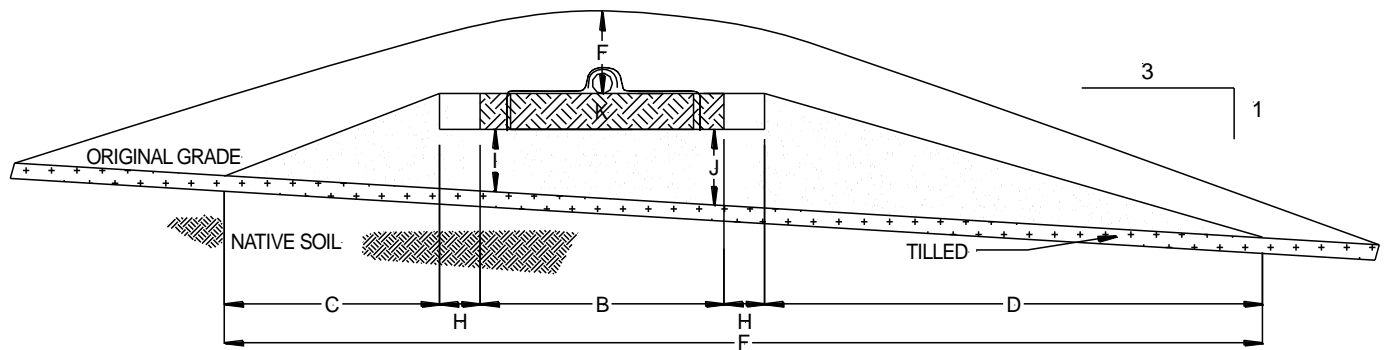

FIGURE 13: PLAN VIEW – MOUND SYSTEM



- A – Dispersal bed length (accounts for sand)
- B – Dispersal bed width – **Minimum 3 ft; Maximum 10 ft**
- C – Distance from edge of dispersal bed to down slope edge of fill
- D – Distance from edge of dispersal bed to up slope edge of fill
- E – Distance from end of dispersal bed to edge of fill
- G – Overall mound fill length
- F – Overall mound fill width
- H – **Minimum 24 in berm**
- I – Up slope fill depth under dispersal bed – **Minimum 1 ft**
- J – Down slope fill depth under dispersal bed – **Minimum 1 ft**
- K – Dispersal bed depth – **Constant 7 in**

6.0 Mound Installation Sizing and Guidelines

6.3 CALCULATE VARIABLES: The following equations are from the Technical Guidance Manual.

1 – Determine soil application rate (AR)	0.6 gpd/ft ²
--	-------------------------

2 – Determine daily flow rate (DFR) DFR = GPD x 1.5	375 gpd
---	---------

Eljen Bed Cell Design

3 - Area = $\frac{\text{Daily Flow Rate (\#2)}}{\text{Sand Application Rate}} = \frac{375 \text{ gpd}}{1.0 \text{ gpd/ft}^2} =$	375 ft ²
---	---------------------

4 – Width (B) = $\sqrt{\frac{\text{Area (\#3)} \times \text{Soil AR (\#1)}}{\text{Sand Application Rate}}}$	
---	--

Maximum bed width = 10 ft

Beds may be designed narrower than determined by this equation if desired. Beds are recommended to be as long and narrow as site conditions allow.

$$\sqrt{\frac{375 \text{ ft}^2 \times 0.5 \text{ gpd/ft}^2}{1 \text{ gpd/ft}^2}} = 13.6 \text{ ft, round down to maximum,} \quad 10 \text{ ft}$$

5 – Length (A) = $\frac{\text{Area (\#3)}}{\text{Width (\#4)}} = \frac{375 \text{ ft}^2}{10 \text{ ft}} =$	37.5 ft
--	---------

0

Sand Mound Design

6 – Total Area = $\frac{\text{DFR (\#2)}}{\text{Soil AR (\#1)}} = \frac{375 \text{ gpd}}{0.6 \text{ gpd/ft}^2} =$	625 ft ²
---	---------------------

7 – Medium sand fill absorption bed perimeter (SFAP) area:

Flat site: SFAP = 2 x (2ft x length (#5))

Sloped Site: SFAP = 2ft x length (#5)

Example = 2 ft x 37.5 ft =	75 ft ²
----------------------------	--------------------

8 – Effluent application area (EAA) = Total area – (bed area + SFAP):

625 ft ² – (375 ft ² + 75 ft ²) =	175 ft ²
---	---------------------

9 – *FLAT SITE ONLY* – Flat site perimeter (C, D): $0.5 \times \left(\frac{\text{EAA (\#8)}}{\text{length (\#5)}}\right)$

Perimeter must maintain a maximum slope of 3:1

Perimeter width must result in a disposal area that meets or exceeds the minimum total area (#6). This will be verified in step 16.

6.0 Mound Installation Sizing and Guidelines

10 – *SLOPED SITE ONLY* – Downslope Length (**D**) = $\left(\frac{\text{EAA (\#8)}}{\text{length (\#5)}}\right) \times \text{DCF}$

Downslope length must result in a maximum slope of 3:1.

Downslope length must result in a disposal area that meets or exceeds the minimum total area (#6). This will be verified in step 17.

Downslope Correction Factors (DCF)																				
Slope (%)	1	2	3	4	5	6	7	8	9	10	11	12	13	14	15	16	17	18	19	20
Correction Factor	1.03	1.06	1.10	1.14	1.18	1.22	1.27	1.32	1.38	1.44	1.51	1.57	1.64	1.72	1.82	1.92	2.04	2.17	2.33	2.50

$$\frac{175 \text{ ft}}{37.5 \text{ ft}} \times 1.14 = 5.32 \text{ ft} \qquad \qquad \qquad 5.32 \text{ ft}$$

11 – *SLOPED SITE ONLY* – Upslope Length (**C**) = $((K + I) \times 3) \times \text{UCF}$

Upslope length must result in a maximum slope of 3:1.

Upslope Correction Factors (UCF)																				
Slope (%)	1	2	3	4	5	6	7	8	9	10	11	12	13	14	15	16	17	18	19	20
Correction Factor	0.97	0.94	0.91	0.89	0.87	0.85	0.83	0.81	0.79	0.77	0.75	0.73	0.72	0.70	0.69	0.67	0.66	0.65	0.64	0.63

K = Constant 0.583 ft

I = 1 ft

$$((0.583 \text{ ft} + 1 \text{ ft}) \times 3) \times 0.89 \qquad \qquad \qquad 4.23 \text{ ft}$$

12 – *FLAT SITES ONLY* – End Slope (**E**) = $(K + I) \times 3$

End slope length must result in a maximum slope of 3:1.

13 – *SLOPED SITES ONLY* – End slope (**E**) = $(J + K) \times 3$

End slope length must result in a maximum slope of 3:1.

$J = I + (\text{Slope of site stated as a decimal} \times \text{Dispersal bed width})$

1 ft + $(0.04 \times 10 \text{ ft}) = 1.4 \text{ ft}$

$$(1.4 \text{ ft} + 0.583 \text{ ft}) \times 3 = \qquad \qquad \qquad 5.95 \text{ ft}$$

14 – Total width (**F**) = $B + C + D + 2 (H)$

H – 2 ft

$$10 \text{ ft} + 5.32 \text{ ft} + 4.23 \text{ ft} + 2 (2 \text{ ft}) = \qquad \qquad \qquad 23.55 \text{ ft}$$

15 – Total length (**G**) = $A + (2 \times E) + 2 (H)$ ($G > F$)

$$37.5 \text{ ft} + (2 \times 5.95 \text{ ft}) + 2 (2 \text{ ft}) \qquad \qquad \qquad 53.4 \text{ ft}$$

Total Area Verification

16 – *FLAT SITES ONLY* - Flat site: Design area (DA) = $A \times F$ ($DA \geq TA$ (#6))

17 - *SLOPED SITES ONLY* – Sloped Site: Design area (DA) = $A \times (B + D + H)$ ($DA \geq TA$ (#6))

$$37.5 \text{ ft} \times (10 \text{ ft} + 5.32 \text{ ft} + 2 \text{ ft}) \qquad \qquad \qquad 774 \text{ ft}^2$$

774 ft² ≥ 625 ft², design area is acceptable.

6.0 Mound Installation Sizing and Guidelines

18 – Sand mound length + 6 ft min. (G + 6)

$$53.4 \text{ ft} + 6 \text{ ft} = 59.4 \text{ ft}$$

19 – Sand mound width + 6 ft min. (F + 6)

$$23.55 \text{ ft} + 6 \text{ ft} = 29.55 \text{ ft}$$

6.4 BED CELL CONSTRUCTION –

Meets the requirements of Section 2.15 of this manual discussing spacing.

Width – 10 ft
 Length – 37.5 ft

Minimum A42s needed for this system: 3 bedrooms x 6 A42s/bedroom = 18 A42 Modules

Units per row: $\frac{\text{Length} - 1}{4 \text{ ft/module}}$

$$\frac{37.5 - 1}{4 \text{ ft/module}} = 9.125, \text{ round down to } 9 \text{ A42 Modules per row}$$

2 Rows are required to meet minimum units required.

Determine End Spacing of A42s inside the dispersal bed:

$$(\text{Dispersal Bed Length} - \text{Modules} \times 4) \div 2$$

$$(125 \text{ ft} - 31 \text{ Modules} \times 4) \div 2 = 0.5 \text{ ft}$$

FIGURE 14: PLAN VIEW – ELJEN BED CELL



6.5 DESIGNER: An Idaho licensed Professional Engineer is required for the design of the Eljen GSF mound system.

6.6 EFFLUENT DISTRIBUTION: The system must be a low pressure distribution system.

6.0 Mound Installation Sizing and Guidelines

1. Ensure all components leading to the GSF system are installed properly. Septic tank effluent filters are required with the GSF system.
2. Determine the number of GSF Modules required using the sizing formula.
3. Prepare the site. Do not install a system on saturated ground or wet soils that are smeared during preparation. Keep machinery off infiltrative areas.
4. Plan all drainage requirements above (up-slope) of the system. Set soil grades to ensure that storm water drainage and ground water is diverted away from the absorption area once the system is complete.
5. Remove the organic soil layer. Scarify the receiving layer to maximize the interface between the native soil and Specified Sand. Minimize walking in the absorption area prior to placement of the Specified Sand to avoid soil compaction.
6. Place fill material meeting local requirements (or Specified Sand requirements) onto the soil interface as you move down the excavated area. Place specified sand in 6" lifts, stabilize by foot, a hand held tamping tool or a portable vibrating compactor. The stabilized height below the GSF module must shall meet the mound design requirements.
7. Place GSF modules with **PAINTED STRIPE FACING UP**, end to end on top of the specified sand along their 4-foot length.
8. A standard perforated 4-inch distribution pipe is centered along the modules 4-inch length. Orifices are set at the 4 & 8 o'clock position.
9. All distribution pipes are secured with manufacturers supplied wire clamps, one per module.
10. Insert a PVC Sch. 40 pressure pipe (size per design and code) into the standard perforated distribution pipe. The pressure pipe orifices are set at the 12 o'clock position as shown in Figure 15. Each pressure lateral will have a drain hole at the 6 o'clock position. Each pressure lateral shall include sweeping cleanouts at the terminal ends and be accessible from grade.

It is strongly recommended to install a 4-inch vent onto the distribution pipe. Distribution pipes can be connected to one vent or use one vent per distribution line.

11. **Cover fabric substitution is not allowed.** The installer should lay the Eljen provided geotextile cover fabric lengthwise down the row, with the fabric fitted to the perforated pipe on top of the GSF modules. Fabric should be neither too loose, nor too tight. The correct tension of the cover fabric is set by:
 - a. Spreading the cover fabric over the top of the module and down both sides of the module with the cover fabric tented over the top of the perforated distribution pipe.
 - b. Place shovelfuls of Specified Sand directly over the pipe area allowing the cover fabric to form a mostly vertical orientation along the sides of the pipe. Repeat this step moving down the pipe.
12. Ensure there is 6 inches of specified sand surrounding the GSF modules in the mound. Slope the sand away from the mound as described on the plan.
13. Complete backfill with a minimum of 12 inches of cover material measured from the top of the module. Use well graded native soil fill that is clean, porous and devoid of large rocks. Do not use wheeled equipment over the system. A light track machine may be used with caution, avoiding crushing or shifting of pipe assembly. Divert surface runoff from the system. Finish grade to prevent surface ponding. Topsoil and seed system area to protect from erosion.
14. Divert surface runoff from the system. Finish grade to prevent surface ponding. Topsoil and seed system area to protect from erosion.

7.0 Dosing Distribution Guidance

DOSING DESIGN CRITERIA: Dosing volume must be set to deliver a maximum of **3 gallons per Module** per dosing cycle, not to exceed 20% of the estimated average daily wastewater flow per TGM 4.19.3.3.3 Dose, No. 4. - Each dose delivered to the infiltrative surface of the drainfield should not exceed 20% of the estimated average daily wastewater flow. Head loss and drain back volume must be considered in choosing the pump size and force main diameter.

8.0 Pressure Distribution Guidance

8.1 SYSTEMS WITH GREATER THAN 1,500 FT² TRENCH AREA: Drainfields larger than 1,500 ft² trench area bottom are prohibited from being constructed as a standard (gravity) drainfield (IDAPA 58.01.03.008.04). Drainfields exceeding 1,500 ft² in total trench bottom area must be pressure dosed (section 4.19 of the Idaho Technical Guidance Manual).

8.2 PRESSURE DISTRIBUTION: Dosing with small diameter pressurized laterals is acceptable for GSF systems. The pipe networks must be engineered and follow principles established for pressure distribution. Flushing ports are required to maintain the free flow of effluent from orifices at the distal ends of each lateral. Contact Eljen's Technical Resource Department at 1-800-444-1359 for more information on pressure distribution systems

Standard procedures for design of pressure distribution networks apply to the GSF filter. Minimum orifice and lateral pipe size is based on design. A drain hole is required at the end of each row at the 6 o'clock position of each pressure lateral for drainage purposes. The lateral pipe network is placed within a standard 4-inch perforated pipe. The perforation in the 4-inch outer pipe are set at the 4 and 8 o'clock position, the drilled orifices on the pressure pipe are set to spray at the 12 o'clock position directly to the top of the 4-inch perforated pipe as shown below.

FIGURE 15: PRESSURE PIPE PLACEMENT

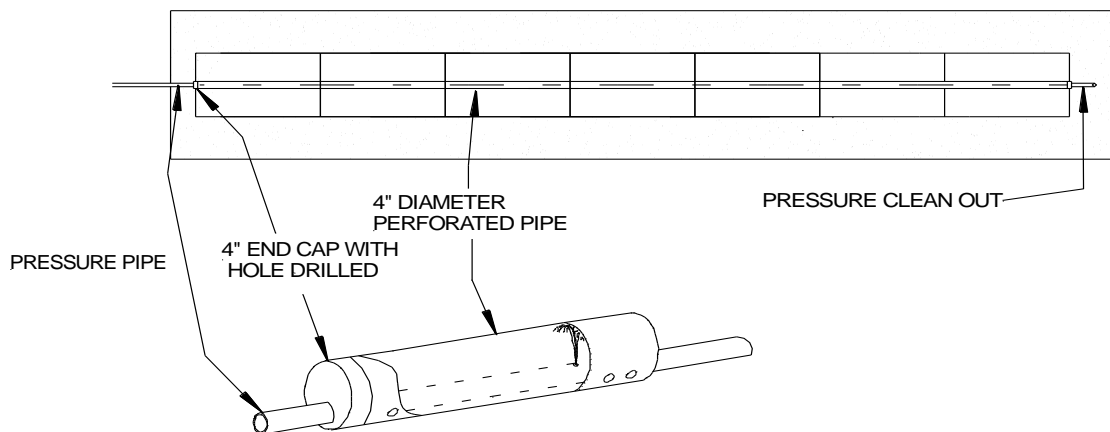

PRESSURE PIPE CROSS SECTION FOR ALL APPLICATIONS

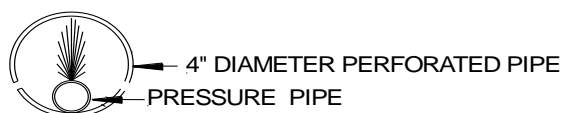

8.0 Pressure Distribution Guidance

FIGURE 16: PRESSURE CLEAN OUT

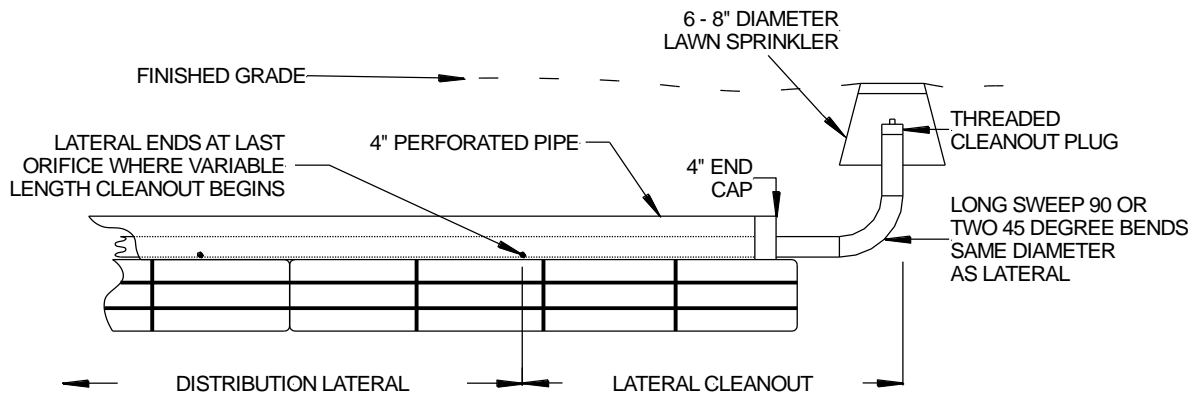
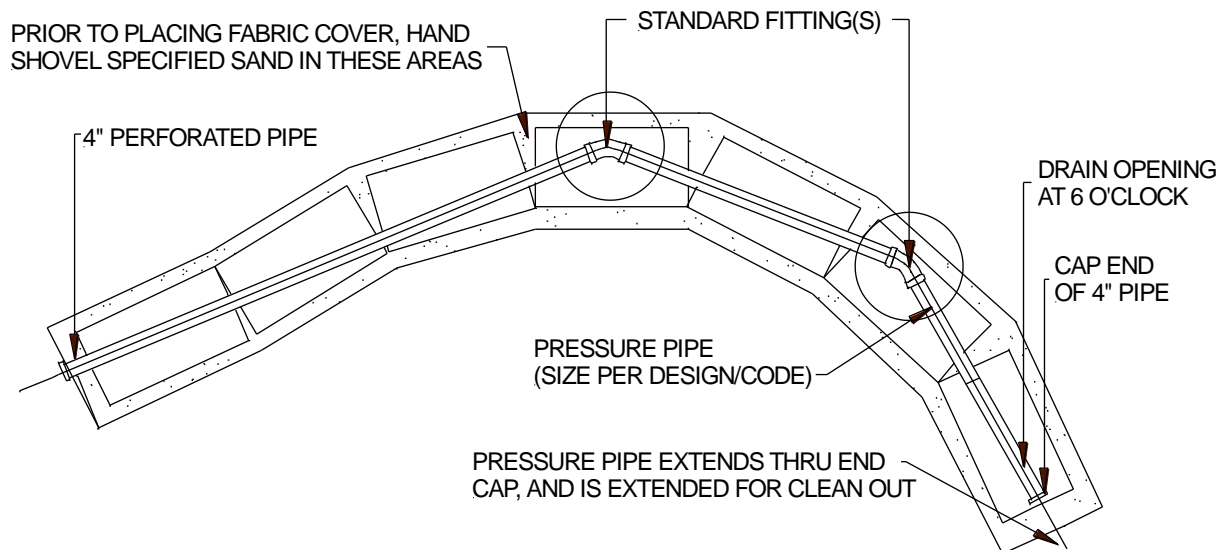

FIGURE 17: CONTOURED TRENCH PRESSURE DISTRIBUTION



GSF Pressure Distribution trench placed on a contour or winding trenches to maintain horizontal separation distances may also be used in Dosed or Gravity system by removing the pressure pipe and using the 4-inch diameter perforated distribution pipe.

9.0 System Ventilation

9.1 SYSTEM VENTILATION: Air vents are required on all absorption systems located under impervious surfaces or systems **with more than 18 inches of cover material** as measured from the top of the GSF module to finished grade. This will ensure proper aeration of the modules and sand filter. The GSF has aeration channels between the rows of GSF modules connecting to cuspatations within the GSF modules. Under normal operating conditions, only a fraction of the filter is in use. The unused channels remain open for intermittent peak flows and the transfer of air.

9.2 VENT PIPE FOR GRAVITY AND LOW-PRESSURE SYSTEMS: Systems with over 18" of cover over the top of the modules require a vent. If the system is a low-pressure distribution system, ensure that the LPP clean outs are located in the vent for easy access.

FIGURE 18: VENT LAYOUTS FOR GRAVITY AND LOW-PRESSURE SYSTEMS

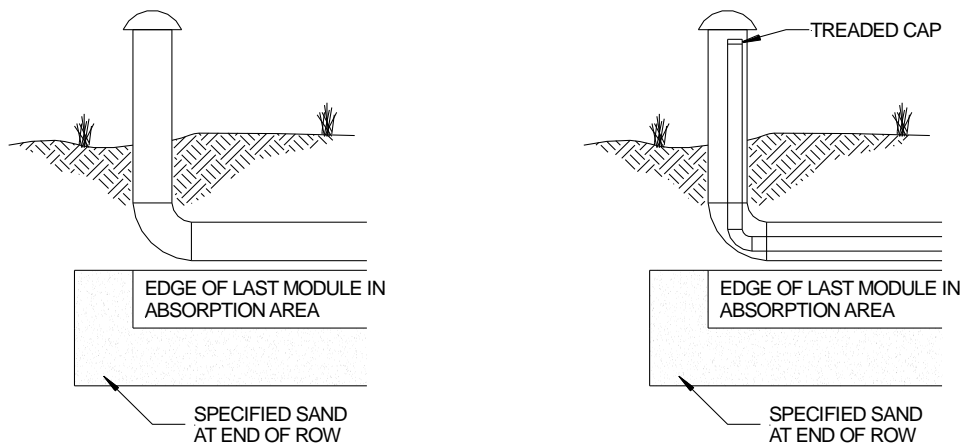

9.3 AIR BY-PASS LINE: Systems with over 18" of cover that are pumped or pressure dosed require an air by-pass line to continue flow from the low vent on the system to the high vent of the house. Simply plumb an airline from the distribution system back to the pump chamber or septic tank to provide unobstructed flow.

FIGURE 19: AIR BY-PASS LINE PLAN VIEW FOR VENTING OF PUMPED SYSTEMS

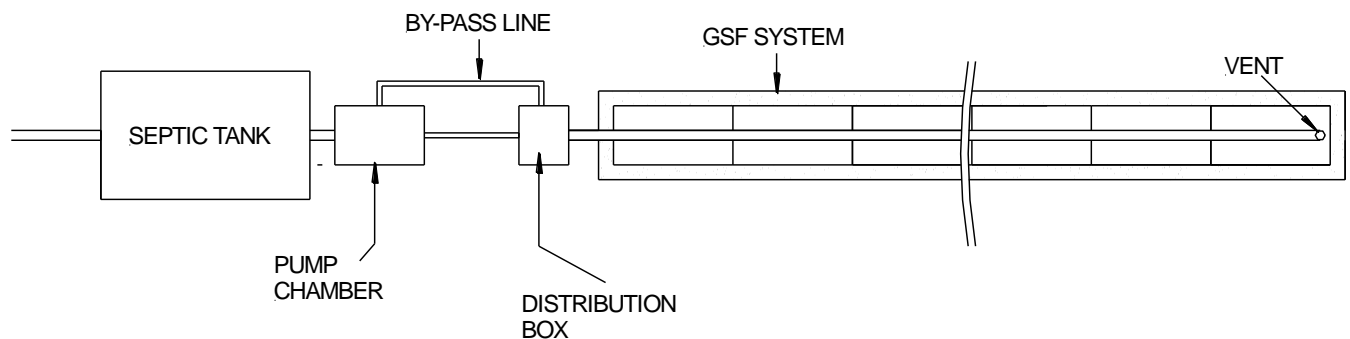

9.0 System Ventilation

9.4 VENTILATION PLACEMENT: In a GSF system, the vent is usually a 4-inch diameter pipe extended to a convenient location behind shrubs, as shown in the figure below. Corrugated pipe may be used. If using corrugated pipe, ensure that the pipe does not have any bends that will allow condensation to pond in the pipe. This may close off the vent line. The pipe must have an invert higher than the system so that it does not drain effluent.

FIGURE 20: GSF WITH 4" VENT EXTENDED TO CONVENIENT LOCATION

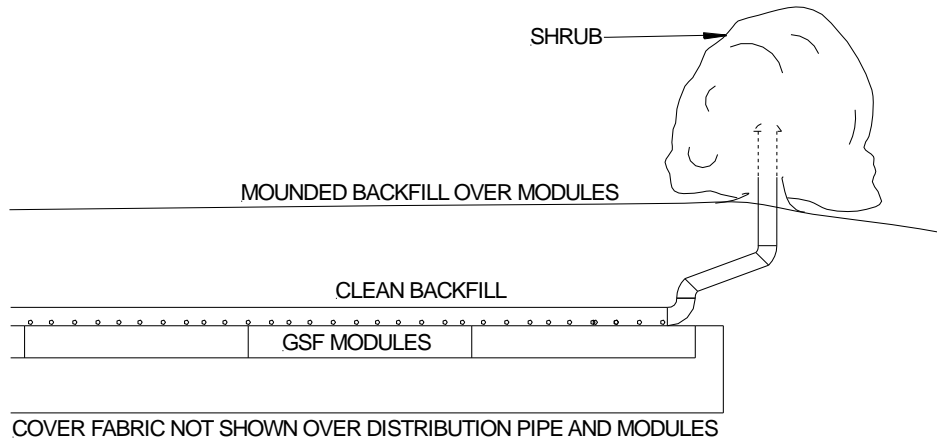

10.0 GSF Inspection Check List

Geotextile Sand Filter, (GSF) Checklist				
Facility Owner:				
Facility Address:				
Installation Date: (MDY)				
Previous Inspection Date: (MDY)				
Date of Inspection: (MDY)				
Residential Number of Bedrooms:				
Is this a Commercial Design? If yes what type:	Yes	No		
What is the estimated BOD5 and TSS strength?	BOD5	TSS	Comments	
Observation Port Location(s):	1	2	3	
Inspection Data, (complete all fields)				
Is daily flow within the system design flow? If no, explain:	Yes	No		
Does the owner verify the system use as described above? If no, explain:	Yes	No		
Septic tank last inspection date:	Date			
Inspected by:				
Septic tank last pumped date:				
Is pumping recommended?	Yes	No		
Condition of the soil absorption system: Wet, Dry, Firm, Soft, Vegetative, or Other. If Other, explain:	W	D	S	F V
Is there evidence of storm water flows or erosion over the septic system? If yes, explain:	Yes	No		

10.0 GSF Inspection Check List

Is there evidence of soil slump or compaction by traffic or other means in the vicinity of the soil absorption system? If yes, describe:	Yes	No	Comments
Is effluent visible through the observation port? If yes, describe the condition and the fluid level:	Yes	No	Comments
Is there a garbage disposal in the home?	Yes	No	Comments
Is a water softer connected to the system?	Yes	No	Comments
Are solids visible through the observation port? If yes, describe the condition and depth of solids:	Yes	No	Comments
Is there evidence of surcharging or effluent ponding in the D-Box? If yes, describe and measure:	Yes	No	Comments
Are the system vents in place?	Yes	No	Comments
Are they operational? If no, describe conditions and location:	Yes	No	
Describe any other pertinent issues:			

Inspected by:	
License Number:	
Date:	
Time:	
Print Name & Signature of Inspector:	
<p><i>I certify I have inspected the system at the above address, completed this report, and the information reported is true, accurate, and complete.</i></p>	

