



**Geotextile Sand Filter**

# B-2 Minnesota Treatment Level Design & Installation Manual



**eljen**  
CORPORATION

*Innovative Onsite Products & Solutions Since 1970*

February 2016  
[www.eljen.com](http://www.eljen.com)

# Table of Contents

---

SUBJECT  
PAGE

GLOSSARY OF TERMS.....	3
GSF SYSTEM DESCRIPTION .....	4
1.0 DESIGN AND INSTALLATION .....	5
2.0 TRENCH INSTALLATION SIZING AND GUIDELINES.....	10
3.0 BED INSTALLATION SIZING AND GUIDELINES .....	13
4.0 LEVEL MOUND SIZING .....	16
5.0 SLOPED MOUND SIZING.....	19
6.0 DISPERSAL BED CONSTRUCTION FOR MOUNDS.....	22
7.0 PRESSURE MOUND INSTALLATION GUIDELINES .....	23
8.0 DOSING DISTRIBUTION GUIDANCE .....	24
9.0 PRESSURE DISTRIBUTION GUIDANCE.....	24
10.0 SYSTEM VENTILATION.....	25
11.0 TREATED EFFLUENT SAMPLING PORT INSTALLATION .....	27
12.0 GSF INSPECTION CHECK LIST .....	29

## GSF DRAWINGS AND TABLES

### DRAWINGS

FIGURE 1: GSF SYSTEM OPERATION .....	4
FIGURE 2: TYPICAL B43 GSF CROSS SECTION.....	5
FIGURE 3: TYPICAL A42 GSF CROSS SECTION.....	5
FIGURE 4: VERTICAL SEPARATION TO RESTRICTIVE LAYER .....	7
FIGURE 5: PLAN VIEW – A42 MODULES – TRENCH SYSTEM.....	11
FIGURE 6: SECTION VIEW – A42 MODULES – TRENCH SYSTEM – LEVEL SITE .....	11
FIGURE 7: SECTION VIEW – A42 MODULES – TRENCH SYSTEM – SLOPING SITE .....	11
FIGURE 8: PLAN VIEW – A42 MODULES – BED SYSTEM .....	14
FIGURE 9: SECTION VIEW – A42 MODULES – BED SYSTEM.....	14
FIGURE 10: PLAN VIEW LEVEL MOUND .....	17
FIGURE 11: CROSS SECTION LEVEL MOUND.....	18
FIGURE 12: PLAN VIEW LEVEL MOUND EXAMPLE .....	18
FIGURE 13: CROSS SECTION LEVEL MOUND EXAMPLE .....	18
FIGURE 14: PLAN VIEW SLOPED MOUND.....	21
FIGURE 15: CROSS SECTION SLOPED MOUND .....	21
FIGURE 16: PLAN VIEW SLOPED MOUND EXAMPLE.....	22
FIGURE 17: CROSS SECTION SLOPED MOUND EXAMPLE.....	22
FIGURE 18: PRESSURE PIPE PLACEMENT .....	24
FIGURE 19: CONTOURED TRENCH PRESSURE DISTRIBUTION.....	25
FIGURE 20: PRESSURE CLEAN OUT PRESSURE DOSED SYSTEMS .....	26
FIGURE 21: GSF WITH 4” VENT EXTENDED TO CONVENIENT LOCATION .....	26
FIGURE 22: SYSTEM SAMPLING PORT LOCATIONS .....	27
FIGURE 23: INSTALLATION OF SAMPLING TUBE STORAGE PIPE.....	28

### TABLES

TABLE 1: SPECIFIED SAND SIEVE REQUIREMENTS.....	3
TABLE 2: SQUARE FOOT PER MODULE.....	7
TABLE 3: LOADING RATES USING PERCOLATION TESTS .....	8
TABLE 4: LOADING RATES USING DETAILED SOIL DESCRIPTIONS.....	9

## Glossary of Terms

---

<b>A42 Module</b>	48" x 24" x 7" (L x W x H)
<b>B43 Module</b>	48" x 36" x 7" (L x W x H)
<b>Cover Fabric</b>	The geotextile cover fabric (provided by manufacturer) that is placed over the GSF modules.
<b>Design Flow</b>	The estimated peak flow that is used to size a GSF system is 150 gallons per day per Bedroom.
<b>GSF</b>	The Eljen Geotextile Sand Filter Modules and the 6-inch sand layer at the base and 6 inches along the sides of the modules.
<b>GSF Module</b>	The individual module of a GSF system. The module is comprised of a cusped plastic core and corrugated geotextile fabric.
<b>Specified Sand</b>	To ensure proper system operation, the system <b>MUST</b> be installed using ASTM C33 Sand.  ASTM C33 sand will have less than 10% passing the #100 Sieve and less than 3% passing the # 200 sieve. Ask your material supplier for a sieve analysis to verify that your material meets the required specifications.

**TABLE 1: SPECIFIED SAND SIEVE REQUIREMENTS**

ASTM C33 SAND SPECIFICATION		
Sieve Size	Sieve Square Opening Size	Specification Percent Passing (Wet Sieve)
3/8 inch	9.52 mm	100
No. 4	4.76 mm	95 - 100
No. 8	2.38 mm	80 - 100
No. 16	1.19 mm	50 - 85
No. 30	590 µm	25 - 60
No. 50	297 µm	5 - 30
No. 100	149 µm	0 - 10
No. 200	75 µm	0 - 5

# GSF System Description

## Primary Treatment Zone

- Perforated pipe is centered above the GSF module to distribute septic effluent over and into corrugations created by the cusped core of the geotextile module.
- Septic effluent is filtered through the Bio-Matt fabric. The module's unique design provides increased surface area for biological treatment that greatly exceeds the module's footprint.
- Open air channels within the module support aerobic bacterial growth on the modules geotextile fabric interface, surpassing the surface area required for traditional absorption systems.
- An anti-siltation geotextile fabric covers the top and sides of the GSF module and protects the Specified Sand and soil from clogging, while maintaining effluent storage within the module.

## Secondary Treatment Zone

- Effluent drips into the Specified Sand layer and supports unsaturated flow into the native soil. This Specified Sand/soil interface maintains soil structure, thereby maximizing the available absorption interface in the native soil. The Specified Sand supports nitrification of the effluent, which reduces oxygen demand in the soil, thus minimizing soil clogging from anaerobic bacteria.
- The Specified Sand layer also protects the soil from compaction and helps maintain cracks and crevices in the soil. This preserves the soil's natural infiltration capacity, which is especially important in finer textured soils, where these large channels are critical for long-term performance.
- Native soil provides final filtration and allows for groundwater recharge.

FIGURE 1: GSF SYSTEM OPERATION

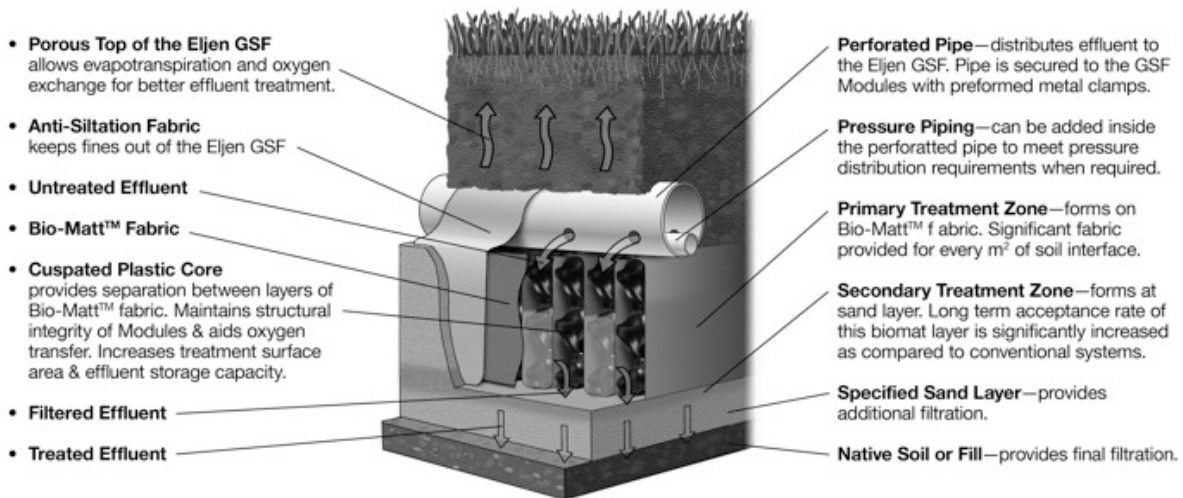

FIGURE 2: TYPICAL B43 GSF CROSS SECTION

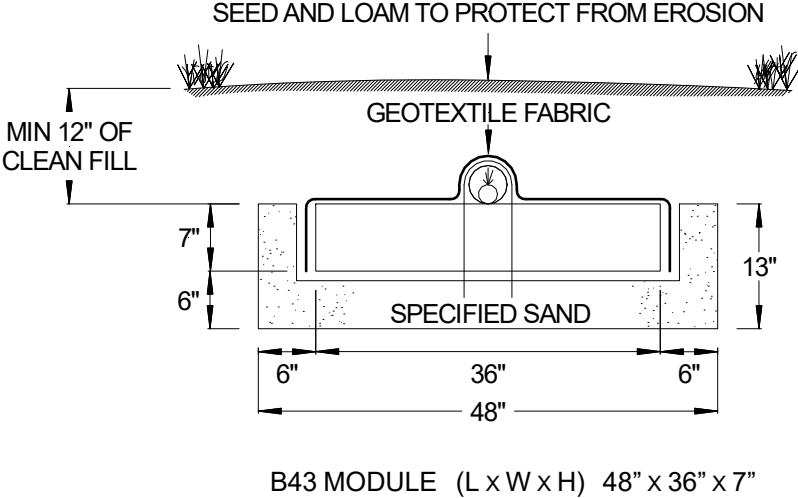
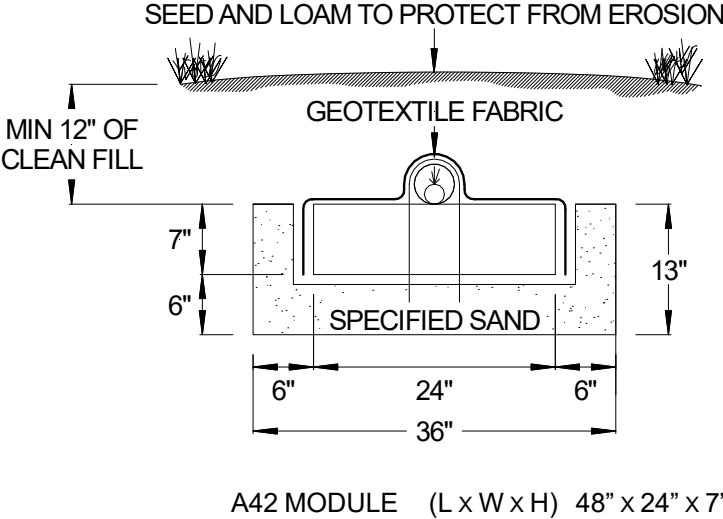

FIGURE 3: TYPICAL A42 GSF CROSS SECTION



**All Systems are Required to Have a Minimum of:**

- 6 inches of Specified Sand is at the edges of the GSF module.
- 6 inches of Specified Sand is at the beginning and end of each GSF Row.
- 6 inches of Specified Sand is directly below the GSF module.
- Minimum 12 inches of native soil fill above the module.

## 1.0 Design and Installation

---

**1.1 REQUIREMENTS:** GSF systems must meet the local rules and regulations except as outlined in this manual. The Minnesota Regulations Chapter 7080 and the local regulations will be referred to as the *guidelines*. The designs in this manual are guided by the design instructions for Treatment Level B-2 in the guidelines.

The sizing charts apply to residential systems only and are found in section 1.16. Please contact Eljen's Technical Resource Department at 1-800-444-1359 for design information on commercial systems.

**1.2 SPECIFIED SAND SPECIFICATION FOR GSF SYSTEMS:** The sand immediately under, between rows and around the perimeter of the GSF system must meet **ASTM C33 SPECIFICATIONS, WITH LESS THAN 10% PASSING A #100 SIEVE AND LESS THAN 3% PASSING A #200 SIEVE**. Please place a prominent note to this effect on each design drawing. See Table 1 for more information on the sand and sieve specifications.

**1.3 CONNECTIONS AND FITTINGS:** Connections of lines to tanks and distribution boxes must be made using watertight mechanical seals. Use of any grouting material is not permitted.

**1.4 PLACING GSF MODULES:** The "Painted Stripe" on the GSF modules indicates the top of the module and is not intended to indicate the location of the distribution pipe. With the painted stripe facing up, all rows of GSF modules are set level, end to end on the Specified Sand layer. No mechanical connection is required between modules.

**1.5 DISTRIBUTION:** Pressure distribution is required when using the GSF System. Two delivery methods are acceptable. Orifice shields are placed over a SCH 40 pipe, one per unit. A second delivery method is also permissible. Using SDR-35 pipe or equivalent; a pressure manifold is placed inside the distribution pipe. Section 4.0 of this manual goes into details of how to construct the distribution network. All piping must meet state and local regulations.

**1.6 COVER FABRIC:** Geotextile cover fabric is provided by Eljen Corporation for all GSF systems. It is placed over the top and sides of the module rows to prevent long term siltation and failure. **Cover fabric substitution is not allowed.** Fabric should drape vertically over the pipe and must not block holes in the distribution pipe or be stretched from the top of the pipe to the outside edge of the modules. "Tenting" will cause undue stress on fabric and pipe.

**1.7 BACKFILL & FINISH GRADING:** Complete backfill with a minimum of 12 inches of clean porous fill measured from the top of the GSF unit. Backfill exceeding 18 inches requires venting at the far end of the trench. Use well graded native soil fill that is clean, porous and devoid of large rocks. Do not use wheeled equipment over the system. A light track machine may be used with caution, avoiding crushing or shifting of pipe assembly. Divert surface runoff from the Effluent Disposal Area, (EDA). Finish grade to prevent surface ponding. Topsoil and seed system area to protect from erosion.

**1.8 ADDITIONAL FACTORS EFFECTING RESIDENTIAL SYSTEM SIZE:** Homes with expected higher than normal water usage may consider increasing the septic tank volume as well as incorporating a multiple compartment septic tank. Consideration for disposal area may be up-sized for expected higher than normal water use.

For example:

- Luxury homes, homes with a Jacuzzi style tubs, and other high use fixtures.
- Homes with known higher than normal occupancy.

**1.9 GARBAGE DISPOSALS:** The use of a garbage disposal is not recommended as they can cause septic system problems by generating an increased amount of suspended solids, grease and nutrients.

However, if such units are proposed to be used, other measures should be taken to mitigate the increased nutrients to the field. Minnesota code requires that systems where a garbage disposal unit is anticipated or installed in a dwelling, the septic tank capacity must be at least 50 percent greater than that required in 7080.1930 subpart 2 of the regulations and must include either multiple compartments or multiple tanks. In addition, an effluent screening device is recommended.

## 1.0 Design and Installation

NOTE: Eljen requires the use of septic tank outlet effluent filters on all systems. Filters with higher filtration are recommended for systems with garbage disposals.

**1.10 SEPTIC TANKS:** Many designers are now specifying dual compartment tanks for all their systems. Eljen supports this practice as it helps to promote long system life by reducing TSS and BOD to the effluent disposal area. Gas baffles and/or effluent filters are also required.

**1.11 SEPTIC TANK FILTERS:** Septic tank effluent filters are **REQUIRED** on the outlet end of septic tank. Filter manufactures require that filters be cleaned from time to time. Ask your installer or designer for specific cleaning requirements based on the type or make of the filter installed. Eljen requires the septic tank to be pumped every three years or as needed which would be a good time to check and conduct filter maintenance.

**1.12 SYSTEM VENTING:** It is strongly recommended to vent all systems that are over 18" below finished grade and systems beneath any surface condition that would not allow for surface air exchange with the system. See Section 6.0 for a more detailed explanation of venting GSF products.

**1.13 VERTICAL SEPARATION TO GROUND WATER OR LIMITING LAYER:** A minimum vertical separation of 36 inches of unsaturated soil or sand between the bottom of the specified sand and the periodically saturated soil level or bedrock. Specified sand may count towards constructability requirements for mounds.

FIGURE 4: VERTICAL SEPARATION TO RESTRICTIVE LAYER

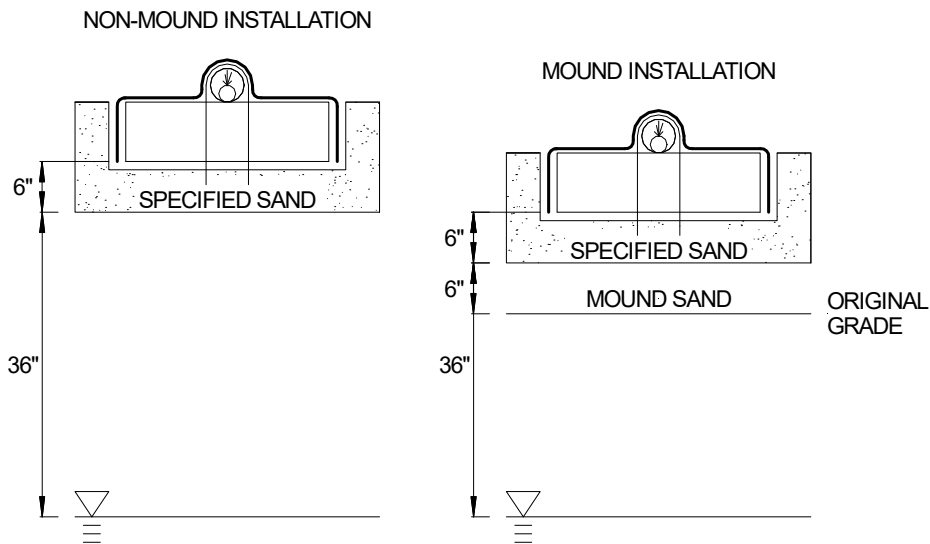

**1.14 NUMBER OF GSF MODULES REQUIRED:** Residential systems use a minimum of six (6) A42 modules per bedroom or five (5) B43 modules per bedroom. See Section 1.16 for more information on systems sizing.

**1.15 BED SYSTEMS:** Bed systems can be no wider than 25 feet. Multiple beds must be horizontally spaced at one-half the bed width.

**1.16 SIZING GSF SYSTEM FOR TRENCHES, BEDS & SAND MOUNDS:**

TABLE 2: SQUARE FOOT PER MODULE

SQUARE FOOT PER MODULE	
A42	12
B43	16

## 1.0 Design and Installation

---

**TABLE 3: LOADING RATES FOR DETERMINING BOTTOM ABSORPTION AREA AND ABSORPTION RATIOS USING PERCOLATION TESTS**

Percolation Rate (MPI)	Treatment Levels A, A-2, B, and B-2 Absorption Area Loading Rate (gpd/ft <sup>2</sup> )	Treatment Levels A, A-2, B, and B-2 Mound Absorption Ratio
<0.1	-	1.0
0.1 to 5	1.6	1.0
0.1 to 5 (fine sand and loamy fine sand)	1.0	1.6
6 to 15	1.0	1.6
16 to 30	0.8	2.0
31 to 45	0.8	2.0
46 to 60	0.6	2.6
61 to 120	0.3	5.3
>120	-	-



## 1.0 Design and Installation

**TABLE 4: LOADING RATES FOR DETERMINING BOTTOM ABSORPTION AREA AND ABSORPTION RATIOS USING DETAILED SOIL DESCRIPTIONS**

USDA Soil Texture	Soil Structure and Grade	Treatment Level A, A-2, B, B-2 Absorption Area Loading Rate (gpd/ft <sup>2</sup> )	Treatment Level A, A-2, B, B-2 Mound Absorption Ratio
Sand, Coarse Sand, Loamy Sand, Loamy Coarse Sand, Fine Sand, Very Fine Sand, Loamy Fine Sand, Loamy Very Fine Sand, 35 to 50% Rock Fragments	Single grain, granular, blocky, or prismatic structure; weak grade	**	1.0
Sand, Coarse Sand, Loamy Sand, Loamy Coarse Sand, <35% Rock Fragments	Single grain, granular, blocky, or prismatic structure; weak grade	1.60	1.0
Fine Sand, Very Fine Sand, Loamy Fine Sand, Loamy Very Fine Sand, <35% Rock Fragments	Single grain, granular, blocky, or prismatic structure; weak grade	1.00	1.6
Sandy Loam, Coarse Sandy Loam, Fine Sandy Loam, Very Fine Sandy Loam	Granular, Blocky or Prismatic Structure; Weak to Strong Grade	1.00	1.6
Sandy Loam, Coarse Sandy Loam, Fine Sandy Loam, Very Fine Sandy Loam	Platy with weak grade or massive	0.87	1.8
Loam	Granular, Blocky or Prismatic Structure; Weak to Strong Grade	0.78	2.1
Loam	Platy with weak grade or massive	0.68	2.4
Silt Loam, Silt	Granular, Blocky or Prismatic Structure; Weak to Strong Grade	0.78	2.1
Silt Loam, Silt	Platy with weak grade or massive	0.65	2.5
Clay Loam, Sandy Clay Loam, Silty Clay Loam	Granular, Blocky or Prismatic Structure; Weak to Strong Grade	0.60	2.7
Clay, Sandy Clay, Silty Clay	-	**	**

## 2.0 Trench Installation Sizing and Guidelines

### Trench Example:

House size:	3 Bedrooms
Classification:	Classification I
Design Flow: From 7080.1860:	450 gpd
Soil Evaluation:	Loam; Blocky
Absorption Field Type:	Trench
Distribution Type:	Pressure Distribution

### Calculate Minimum Absorption Area

Lookup loading rate from Table 5 and determine the application rate:

USDA Soil Texture	Soil Structure and Grade	Treatment Level B	Treatment Level B
		Absorption Area Loading Rate (gpd/ft <sup>2</sup> )	Mound Absorption Ratio
Loam	Granular, Blocky or Prismatic Structure; Weak to Strong Grade	0.78	2.1

Absorption Area: Design Flow ÷ Loading Rate

$$450 \text{ gpd} \div 0.78 \text{ gpd} / \text{ft}^2 = 576.9 \text{ ft}^2, \text{ round to } 577 \text{ ft}^2$$

### Calculate Number of Modules Required

SQUARE FOOT PER MODULE	
A42	12

Number of units required = Absorption Area ÷ Square Foot Per Module

### A42 units required

$$577 \text{ ft}^2 \div 12 \text{ ft}^2 / \text{module} = 48 \text{ Modules}$$

Round to: 48 A42 Modules

### Calculate Minimum Trench Length

$$\text{A42: } 48 \text{ Units} \times 4 \text{ ft/unit} = 192 \text{ linear ft}$$

### Trench Width

$$\text{A42: } 3 \text{ ft}$$

### Final Dimension Layout

(Note: System layout and number of rows will vary based on site constraints)

### A42

Min. Product Length	192 ft
(note: 6 inches of sand required at each end of trench which makes the minimum trench length 193 ft)	
Trench Width	3 ft
Minimum Number of Units	48 A42 Modules
Min. System Area	579 ft <sup>2</sup>

## 2.0 Trench Installation Sizing and Guidelines

FIGURE 5: PLAN VIEW – A42 MODULES – TRENCH SYSTEM

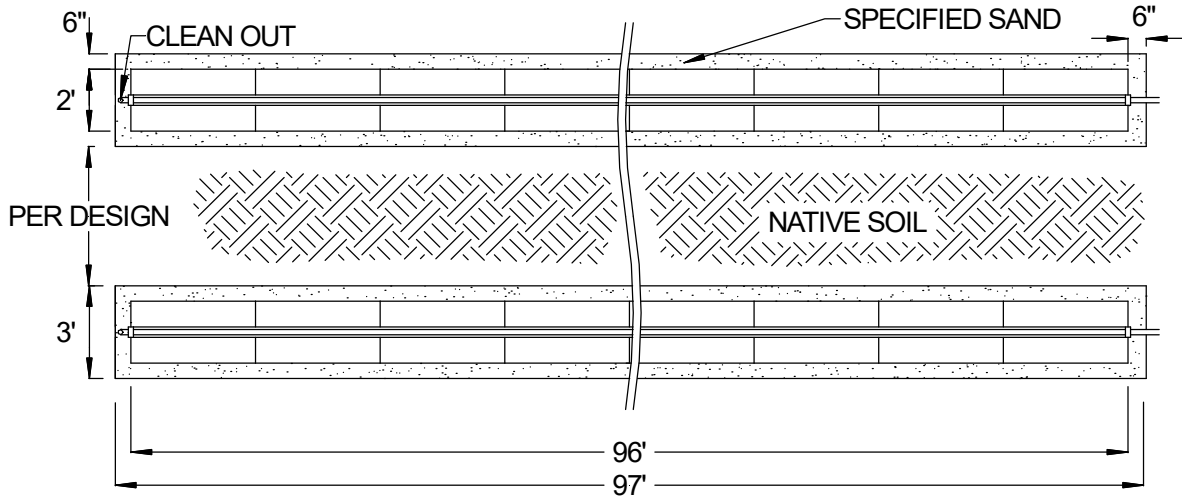

FIGURE 6: SECTION VIEW – A42 MODULES – TRENCH SYSTEM – LEVEL SITE

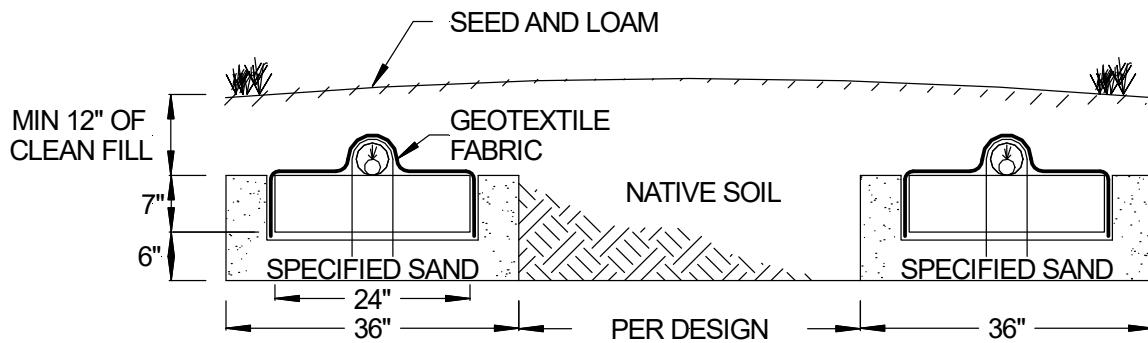
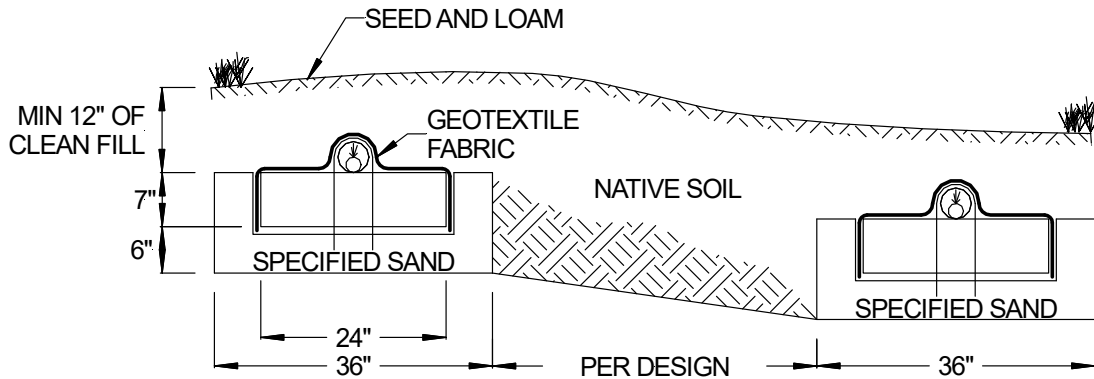

FIGURE 7: SECTION VIEW – A42 MODULES – TRENCH SYSTEM – SLOPING SITE



## 2.0 Trench Installation Sizing and Guidelines

<b>Trench Installation Guidelines</b> Additional guidance in State and Local regulations	
Determine the Number Modules	Determine the number of GSF Modules required using the trench sizing example.
Plan all Drainage Requirements	Plan all drainage requirements above (up-slope) of the system. Set soil grades to ensure that storm water drainage and ground water is diverted away from the absorption area once the system is complete.
Excavating the Trench Area	Scarify the receiving layer to maximize interface between the native soil and Specified Sand. Minimize walking in the trench prior to placement of the Specified Sand to avoid soil compaction.
Placing Specified Sand Base	Place Specified Sand in a 6 inch lift, stabilize and level. The stabilized height below the GSF module must be level at 6 inches. A hand tamping tool or vibrating compactor are both acceptable.
Place GSF Modules	Place the GSF Modules, <b><i>PAINTED STRIPE FACING UP</i></b> , end to end on top of the Specified Sand along their 4-foot length.
Distribution Pipes	A standard 4-inch perforated pipe, SDR 35 or equivalent, is centered along the modules 4-foot length. Orifices are set at the 4 & 8 o'clock position. Insert a pressure pipe (size per design and code) into the standard 4-inch perforated pipe. The pressure pipe orifices are set at the 12 o'clock position as shown in Figure 18. Each pressure lateral will have a drain hole at the 6 o'clock position. Each pressure lateral shall have a clean out at the end of the trench. All 4-inch pipes are secured with manufacturers supplied wire clamps, one per module.
Place Geotextile Cover Fabric	<p><b><i>Cover fabric substitution is not allowed.</i></b> The installer should lay the Eljen provided geotextile cover fabric lengthwise down the trench, with the fabric fitted to the perforated pipe on top of the GSF modules. Fabric should be neither too loose, nor too tight. The correct tension of the cover fabric is set by:</p> <ul style="list-style-type: none"> <li>• Spreading the cover fabric over the top of the module and down both sides of the module with the cover fabric tented over the top of the perforated distribution pipe.</li> <li>• Place shovelful's of Specified Sand directly over the pipe area allowing the cover fabric to form a mostly vertical orientation along the sides of the pipe. Repeat this step moving down the pipe.</li> </ul>
Placing Specified Sand after Cover Fabric is in place	Place 6 inches of Specified Sand along both sides of the modules edge. A minimum of 6 inches of Specified Sand is placed at the beginning and end of each trench.
Backfilling the System	Complete backfill with a minimum of 12 inches of clean porous fill measured from the top of modules. Backfill exceeding 18 inches requires venting at the far end of the trench or bed. Use well graded native soil fill that is clean, porous and devoid of large rocks. Do not use wheeled equipment over the system. A light track machine may be used with caution, avoiding crushing or shifting of pipe assembly. Divert surface runoff from the system. Finish grade to prevent surface ponding. Topsoil and seed system area to protect from erosion.

### 3.0 Bed Installation Sizing and Guidelines

**Bed Example:**

House size:	3 Bedrooms
Classification:	Classification I
Design Flow: From 7080.1860:	450 gpd
Soil Evaluation:	Loam; Blocky
Absorption Field Type:	Bed
Distribution Type:	Pressure Distribution

**Calculate Minimum Absorption Area**

Lookup loading rate from Table 5 and determine the application rate:

USDA Soil Texture	Soil Structure and Grade	Treatment Level B	Treatment Level B
		Absorption Area Loading Rate (gpd/ft <sup>2</sup> )	Mound Absorption Ratio
Loam	Granular, Blocky or Prismatic Structure; Weak to Strong Grade	0.78	2.1

Absorption Area = Design Flow ÷ Loading Rate

450 gpd ÷ 0.78 gpd / ft<sup>2</sup> = 576.9 ft<sup>2</sup>, round to 577 ft<sup>2</sup>

**Determine Number of Modules Required**

Lookup square foot per module from Table 2:

SQUARE FOOT PER MODULE	
A42	12
B43	16

Units Required = Absorption Area ÷ Square Foot per Module

**A42 units required**

577 ft<sup>2</sup> ÷ 12 ft<sup>2</sup>/module = 48 A42 Modules

**B43 units required**

577 ft<sup>2</sup> ÷ 16 ft<sup>2</sup>/module = 36 B43 Modules

**Calculate Minimum Bed Length**

2 Rows – Modules per Row  
 A42: 48 Units ÷ 2 Rows = 24 Mods/Row  
 Row Length: Modules x 4 ft / module + 1  
 24 Modules x 4 ft / module + 1 = 97 ft

2 Rows – Modules per Row  
 B43: 36 Units ÷ 2 Rows = 18 Mods/Row  
 Row Length: Units x 4 + 1  
 18 Modules x 4 ft / module + 1 = 73 ft

3 Rows – Modules per Row  
 A42: 48 Units ÷ 3 Rows = 16 Mods/Row  
 Row Length: Modules x 4 ft / module + 1  
 16 Modules x 4 ft / module + 1 = 65 ft

3 Rows – Modules per Row  
 B43: 36 Units ÷ 3 Rows = 12 Mods/Row  
 Row Length: Units x 4 + 1  
 12 Modules x 4 ft / module + 1 = 49 ft

### 3.0 Bed Installation Sizing and Guidelines

#### Bed Width

Bed systems can be no wider than 25 feet. Multiple beds must be horizontally spaced at one-half the bed width. Determine the bed width you would like to use and it will determine the rest of your bed dimensions. Maintain a minimum of 2 rows in a bed system.

BED WIDTH PER ROW	
A42	3
B43	4

Bed Width = Rows in Bed x Bed Width per Row

2 Rows

A42: 2 Rows x 3 ft/Row = 6 ft

2 Rows  
B43: 2 Rows x 4 ft/Row = 8 ft

3 Rows

A42: 3 Rows x 3 ft/Row = 9 ft

3 Rows  
B43: 3 Rows x 4 ft/Row = 12 ft

#### Final Dimension Layout

(Note: System layout and number of rows will vary based on site constraints)

##### A42 – 2 Row

Bed Length	97 ft
Bed Width	6 ft
Minimum Number of Units	48 A42 Units
Units per Row	24 units per row
System Area	582 ft <sup>2</sup>

##### B43 – 2 Row

Bed Length	73 ft
Bed Width	8 ft
Minimum Number of Units	36 B43 Units
Units per Row	18 units per row
System Area	584 ft <sup>2</sup>

FIGURE 8: PLAN VIEW – A42 MODULES – BED SYSTEM

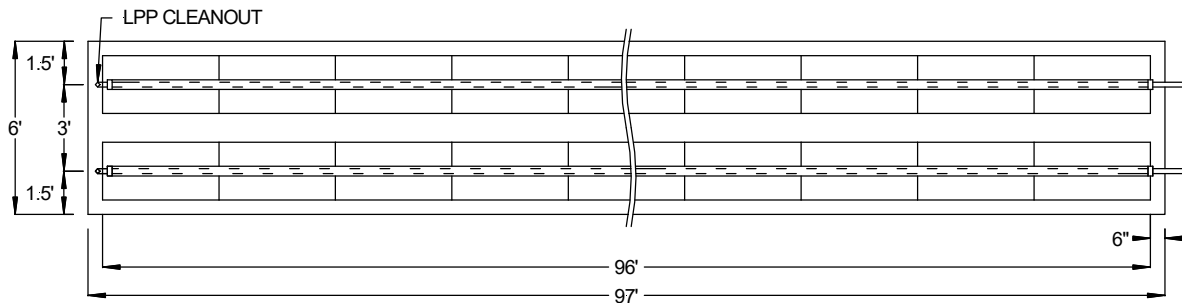
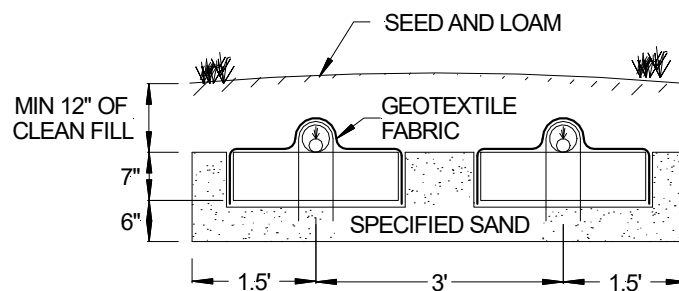

FIGURE 9: SECTION VIEW – A42 MODULES – BED SYSTEM



### 3.0 Bed Installation Sizing and Guidelines

<b>Bed Installation Guidelines</b>	
Additional guidance in State and Local regulations	
Determine the Number Modules	Determine the number of GSF Modules required using the mound sizing example.
Excavating the Bed Area	Scarify the receiving layer to maximize the interface between the native soil and Specified Sand. Minimize walking in the absorption area prior to placement of the Specified Sand to avoid soil compaction.
Placing Specified Sand Base	Place Specified Sand in a 6 inch lift, stabilize and level. The stabilized height below the GSF module must be level at 6 inches. A hand tamping tool or vibrating compactor are both acceptable.
Place GSF Modules	Place the GSF Modules, <b>PAINTED STRIPE FACING UP</b> , end to end on top of the Specified Sand along their 4-foot length.
Distribution Pipes	A standard 4-inch perforated pipe, SDR 35 or equivalent, is centered along the modules 4-foot length. Orifices are set at the 4 & 8 o'clock position. Insert a pressure pipe (size per design and code) into the standard 4-inch perforated pipe. The pressure pipe orifices are set at the 12 o'clock position as shown in Figure 18. Each pressure lateral will have a drain hole at the 6 o'clock position. Each pressure lateral shall have a clean out at the end of the trench. All 4-inch pipes are secured with manufacturers supplied wire clamps, one per module.
Place Geotextile Cover Fabric	<p><b>Cover fabric substitution is not allowed.</b> The installer should lay the Eljen provided geotextile cover fabric lengthwise down the trench, with the fabric fitted to the perforated pipe on top of the GSF modules. Fabric should be neither too loose, nor too tight. The correct tension of the cover fabric is set by:</p> <ul style="list-style-type: none"> <li>• Spreading the cover fabric over the top of the module and down both sides of the module with the cover fabric tented over the top of the perforated distribution pipe.</li> <li>• Place shovelful's of Specified Sand directly over the pipe area allowing the cover fabric to form a mostly vertical orientation along the sides of the pipe. Repeat this step moving down the pipe.</li> </ul>
Placing Specified Sand after Cover Fabric is in place	Place 6 inches of Specified Sand along both sides of the modules edge. A minimum of 6 inches of Specified Sand is placed at the beginning and end of each trench.
Backfilling the System	Complete backfill with a minimum of 12 inches of clean porous fill measured from the top of modules. Backfill exceeding 18 inches requires venting at the far end of the trench or bed. Use well graded native soil fill that is clean, porous and devoid of large rocks. Do not use wheeled equipment over the system. A light track machine may be used with caution, avoiding crushing or shifting of pipe assembly. Divert surface runoff from the system. Finish grade to prevent surface ponding. Topsoil and seed system area to protect from erosion.

## 4.0 Level Mound Sizing

---

### Level Mound Example:

House size:	3 Bedrooms
Classification:	Classification I
Soil Evaluation:	Loam; Blocky
Depth to Limiting Condition	36 inches
Site Slope	0%
Berm Ratio	4:1
Absorption Field Type:	Level Mound
Distribution Type:	Pressure Distribution

### 1.A: Daily Design Flow

450 gpd

Design Flow: From 7080.1860:

### 1.B: In situ soil application rate

USDA Soil Texture	Soil Structure and Grade	Treatment Level B	Treatment Level B
		Absorption Area Loading Rate (gpd/ft <sup>2</sup> )	Mound Absorption Ratio
Loam	Granular, Blocky or Prismatic Structure; Weak to Strong Grade	0.78	2.1

### 1.C: Depth to Limiting Condition

36 inches

### 1.D: Site Slope

0%

### 1.E: Design Media Loading Rate

1.6 gpd/ft<sup>2</sup>

### 1.F: Mound Absorption Ratio

2.1

### Eljen GSF Media Sizing

#### 2.A: Dispersal Bed Area = 1.A ÷ 1.E

450 gpd ÷ 1.6 gpd/ft<sup>2</sup> =

281.25 ft<sup>2</sup>

#### 2.B: Dispersal Bed Width (cannot exceed 10 ft)

3 ft

#### 2.C: Contour Loading Rate = 2.B x 1.E (if greater than 12, reduce Dispersal Bed Width in 2.B)

3 ft x 1.6 gpd/ft<sup>2</sup> =

4.8 gal/ft

#### 2.D: Dispersal Bed Length = 2.A ÷ 2.C

281.25 ft<sup>2</sup> ÷ 3 ft =

93.75 ft

### Absorption Area Sizing

#### 3.A: Absorption Width = 2.B ÷ 1.F

3 ft x 2.1 =

6.3 ft

#### 3.B: Absorption Width Beyond Bed = (3.A – 2.B) ÷ 2

(6.3 ft – 3 ft) ÷ 2 = (3.3 ft) ÷ 2 =

1.65 ft



## 4.0 Level Mound Sizing

### Mound Sizing

**6.A: Clean Sand Lift = 48 inches – 1.C**

48 inches – 36 inches = 12 inches, convert to feet 1 ft

**6.B: Mound Height = 6.A + 1.58 ft (1.58 = Height of Unit + Cover at Edge of Mound)**

1 ft + 1.58 ft = 2.58 ft

**6.C: Berm Width = 6.B x Berm Ratio**

2.58 ft x 4 = 10.32 ft

**6.D: Total Landscape Width = 2.B + (2 x 6.C)**

3 ft + (2 x 10.32 ft) = 3 ft + (20.64 ft) = 23.64 ft

**6.E: Additional Berm Width (if 3.A – 6.D is 0 or less, 0 ft, otherwise 3.A – 6.D)**

6.3 ft – 23.64 ft = -17.34, therefore 0 ft

**6.F: Final Berm Width = 6.C + 6.E**

10.32 ft + 0 ft = 10.32 ft

**6.G: Total Mound Width = (2 x 6.F) + 2.B**

(2 x 10.32 ft) + 3 ft = (20.64 ft) + 3 ft = 23.64 ft

**6.H: Total Mound Length = (2 x 6.F) + 2.D**

(2 x 10.32 ft) + 93.75 ft = (20.64 ft) + 93.75 ft = 114.39 ft

**6.I: Setbacks from the Bed = (3.A – 2.B) ÷ 2**

(6.3 ft – 3 ft) ÷ 2 = (3.3 ft) ÷ 2 = 1.65 ft

FIGURE 10: PLAN VIEW LEVEL MOUND

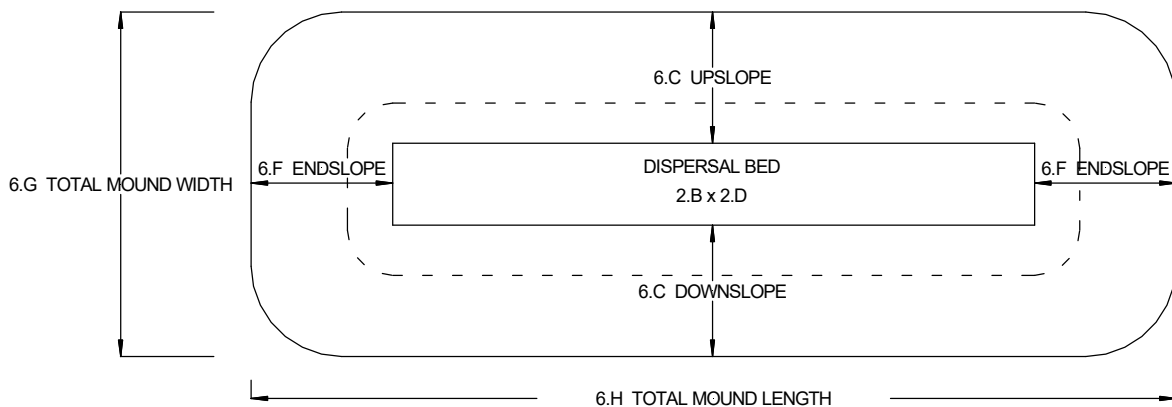

## 4.0 Level Mound Sizing

FIGURE 11: CROSS SECTION LEVEL MOUND

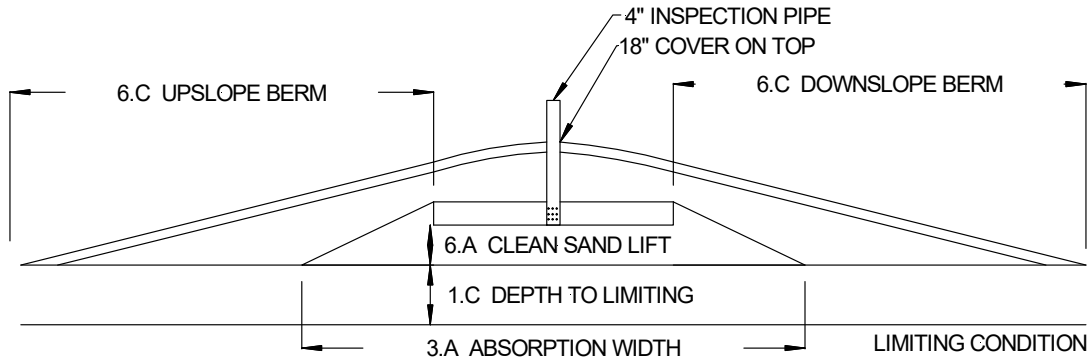

FIGURE 12: PLAN VIEW LEVEL MOUND EXAMPLE

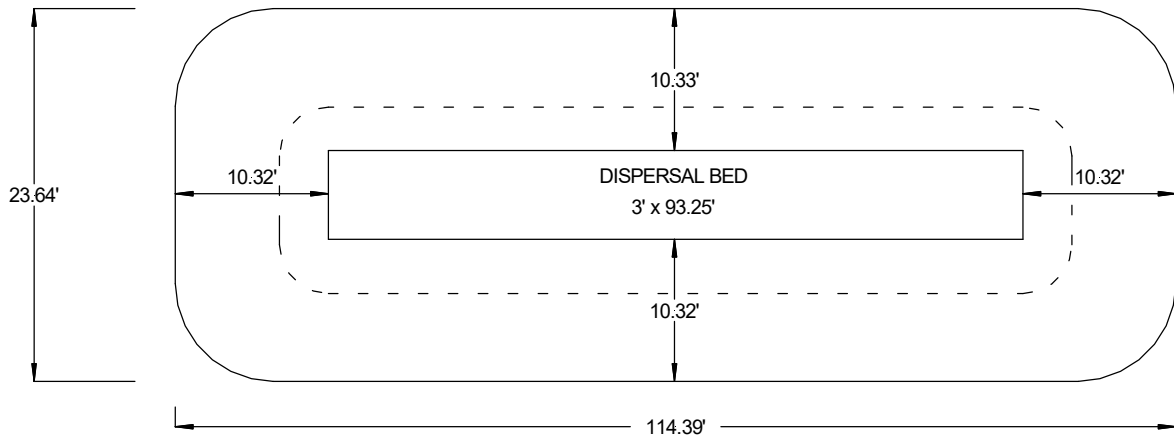
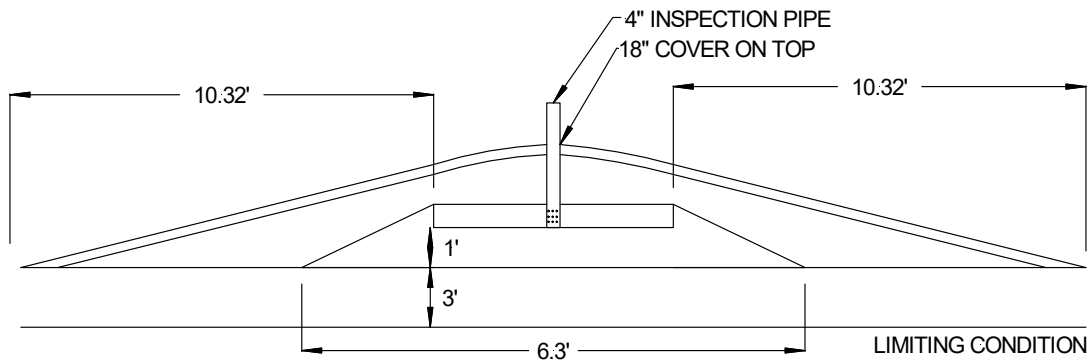

FIGURE 13: CROSS SECTION LEVEL MOUND EXAMPLE



## 5.0 Sloped Mound Sizing

### Level Mound Example:

House size:	3 Bedrooms
Classification:	Classification I
Soil Evaluation:	Loam; Blocky
Depth to Limiting Condition	36 inches
Site Slope	5%
Berm Ratio	4:1
Absorption Field Type:	Sloped Mound
Distribution Type:	Pressure Distribution

### 1.A: Daily Design Flow

450 gpd

Design Flow: From 7080.1860:

### 1.B: In situ soil application rate

USDA Soil Texture	Soil Structure and Grade	Treatment Level B	Treatment Level B
		Absorption Area Loading Rate (gpd/ft <sup>2</sup> )	Mound Absorption Ratio
Loam	Granular, Blocky or Prismatic Structure; Weak to Strong Grade	0.78	2.1

### 1.C: Depth to Limiting Condition

36 inches

### 1.D: Site Slope

5%

### 1.E: Design Media Loading Rate

1.6 gpd/ft<sup>2</sup>

### 1.F: Mound Absorption Ratio

2.1

### Eljen GSF Media Sizing

#### 2.A: Dispersal Bed Area = 1.A ÷ 1.E

450 gpd ÷ 1.6 gpd/ft<sup>2</sup> =

281.25 ft<sup>2</sup>

#### 2.B: Dispersal Bed Width (cannot exceed 10 ft)

3 ft

#### 2.C: Contour Loading Rate = 2.B x 1.E (if greater than 12, reduce Dispersal Bed Width in 2.B)

3 ft x 1.6 gpd/ft<sup>2</sup> =

4.8 gal/ft

#### 2.D: Dispersal Bed Length = 2.A ÷ 2.B

281.25 ft<sup>2</sup> ÷ 3 ft =

93.75 ft

### Absorption Area Sizing

#### 3.A: Absorption Width = 2.B ÷ 1.F

3 ft x 2.1 =

6.3 ft

#### 3.B: Downslope Absorption Width Beyond Bed = (3.A – 2.B)

6.3 ft – 3 ft =

3.3 ft

## 5.0 Sloped Mound Sizing

---

### Mound Sizing

#### 6.A: Clean Sand Lift = 48 inches – 1.C

48 inches – 36 inches = 12 inches, convert to feet 1 ft

#### 6.B: Upslope Mound Height = 6.A + 1.58 ft (Height of Unit + Cover at Edge of Mound)

1 ft + 1.58 ft = 2.58 ft

#### 6.C: Upslope Berm Multiplier

Land Slope %		0	1	2	3	4	5	6	7	8	9	10	11	12
Upslope Berm Ratio	3:1	3.00	2.91	2.83	2.75	2.68	2.61	2.54	2.48	2.42	2.36	2.31	2.26	2.21
	4:1	4.00	3.85	3.70	3.57	3.45	3.33	3.23	3.12	3.03	2.94	2.86	2.78	2.70

We used the 4:1 ratio as that was specified in the example conditions.

#### 6.D: Upslope Berm Width = 6.C x 6.B

3.33 x 2.58 ft = 8.59 ft

#### 6.E: Drop in Elevation Under Bed = 2.B x 1.D

3 ft x .05 = 0.15 ft

#### 6.F: Downslope Mound Height = 6.B + 6.E

2.58 ft + 0.15 ft = 2.73 ft

#### 6.G: Downslope Berm Multiplier

Land Slope %		0	1	2	3	4	5	6	7	8	9	10	11	12
Downslope Berm Ratio	3:1	3.00	3.09	3.19	3.30	3.41	3.53	3.66	3.80	3.95	4.11	4.29	4.48	4.69
	4:1	4.00	4.17	4.35	4.54	4.76	5.00	5.26	5.56	5.88	6.25	6.67	7.14	7.69

We used the 4:1 ratio as that was specified in the example conditions.

#### 6.H: Downslope Berm Width = 6.G x 6.F

5.00 x 2.73 ft = 13.65 ft

#### 6.I: Berm to Cover Absorption Area = 3.B + 4 ft

3.3 ft + 4 ft = 7.3 ft

#### 6.J: Downslope Berm = either 6.H or 6.I, whichever is larger

13.65 ft > 7.3 ft 13.65 ft

#### 6.K: Berm Multiplier = usually 3.0 or 4.0

We used the 4:1 ratio as that was specified in the example conditions. 4.0

#### 6.L: Endslope Berm Width = 6.K x 6.F

4.0 x 2.73 ft 10.92 ft

#### 6.M: Mound Width = 6.D + 2.B + 6.H

8.59 ft + 3 ft + 13.65 ft 25.24 ft

#### 6.N: Mound Length = 6.L + 2.D + 6.L

10.92 ft + 93.75 ft + 10.92 ft 115.59 ft

## 5.0 Sloped Mound Sizing

---

FIGURE 14: PLAN VIEW SLOPED MOUND

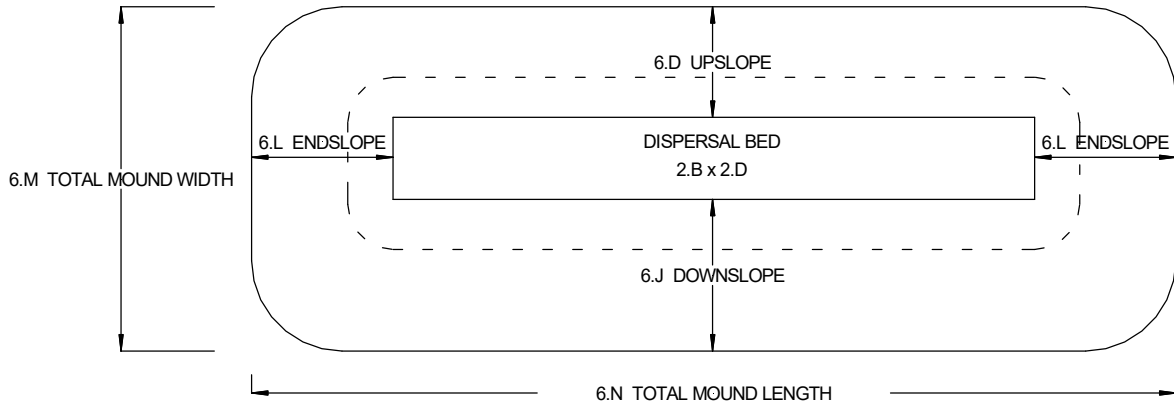
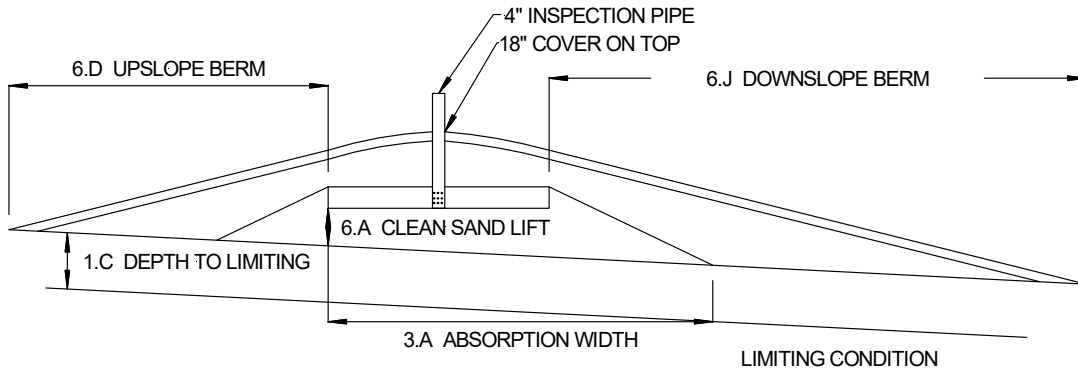

FIGURE 15: CROSS SECTION SLOPED MOUND



## 5.0 Sloped Mound Sizing

FIGURE 16: PLAN VIEW SLOPED MOUND EXAMPLE

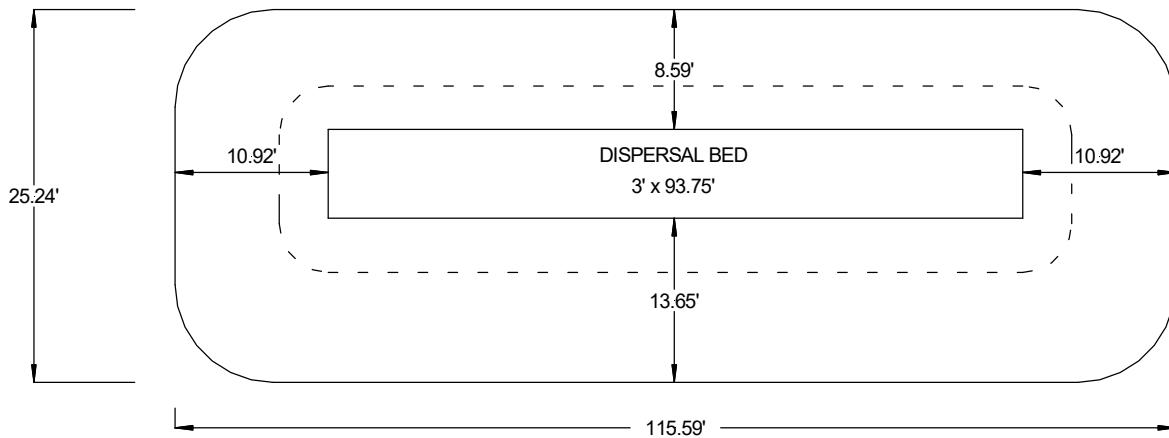
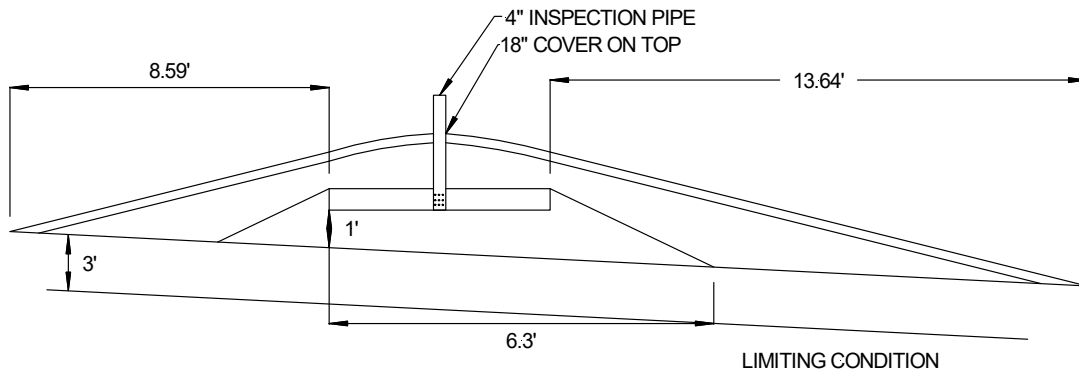

FIGURE 17: CROSS SECTION SLOPED MOUND EXAMPLE



## 6.0 Dispersal Bed Construction for Mounds

**DISPERSAL BED SIZING:** Dispersal beds require a minimum of 3 feet in width and can go up to a maximum of 10 feet in width. Units are required to have a minimum of 6 inches surrounding the end of the system and the sides of the unit. The maximum amount of sand to the sides of the units is one foot. Units and sand are required to fill the entire dispersal bed.

**A42 UNITS:** Have a minimum width of 3 feet when used in a Dispersal Bed. A42 units may be used in a maximum of 4 feet width which will give them 12 inches of sand to the sides of the unit.

**B43 UNITS:** Have a minimum width of 4 feet when used in a Dispersal Bed. B43 units may be used in a maximum of 5 feet width which will give them 12 inches of sand to the sides of the unit.

**UNITS REQUIRED:** Units are 4 feet long. Divide the Dispersal Bed Length by 4 and round down to determine the units required per row. This is the only time it is acceptable to round down to the nearest whole number of modules required. Keep equal distance from the ends of the Dispersal Bed when placing the unit rows. Multiply the number of units required per row and that will determine the number of units required.

## 7.0 Pressure Mound Installation Guidelines

<b>Pressure Mound Installation Guidelines</b> Additional guidance in State and Local regulations	
Determine the Number Modules	Determine the number of GSF Modules required using the mound sizing example.
Excavating the Bed Area	Scarify the receiving layer to maximize the interface between the native soil and Specified Sand. Minimize walking in the absorption area prior to placement of the Specified Sand to avoid soil compaction.
Placing Specified Sand Base	Place Specified Sand in two 6 inch lifts. Stabilize and level each lift. The stabilized height below the GSF module must be level at 12 inches. A hand tamping tool or vibrating compactor are both acceptable.
Place GSF Modules	Place the GSF Modules, <b>PAINTED STRIPE FACING UP</b> , end to end on top of the Specified Sand along their 4-foot length.
Distribution Pipes:	A standard 4-inch perforated pipe, SDR 35 or equivalent, is centered along the modules 4-foot length. Orifices are set at the 4 & 8 o'clock position. Insert a pressure pipe ( <i>size per design and code</i> ) into the standard 4-inch perforated pipe. The pressure pipe orifices are set at the 12 o'clock position as shown in Figure 18. Each pressure lateral will have a drain hole at the 6 o'clock position. All 4-inch pipes are secured with manufacturers supplied wire clamps, one per module.
Pump Chamber to the GSF System	Refer to local regulations for guidance <ul style="list-style-type: none"> <li>· Pressure Distribution Guidance</li> <li>· Pump Controls</li> </ul>
Place Geotextile Cover Fabric	<p><b>Cover fabric substitution is not allowed.</b> The installer should lay the Eljen provided geotextile cover fabric lengthwise down the trench, with the fabric fitted to the perforated pipe on top of the GSF modules. Fabric should be neither too loose, nor too tight. The correct tension of the cover fabric is set by:</p> <ul style="list-style-type: none"> <li>• Spreading the cover fabric over the top of the module and down both sides of the module with the cover fabric tented over the top of the perforated distribution pipe.</li> <li>• Place shovelful's of Specified Sand directly over the pipe area allowing the cover fabric to form a mostly vertical orientation along the sides of the pipe. Repeat this step moving down the pipe.</li> </ul>
Backfilling the System	Complete backfill with a minimum of 12 inches of clean porous fill measured from the top of modules. Backfill exceeding 18 inches requires venting at the far end of the trench or bed. Use well graded native soil fill that is clean, porous and devoid of large rocks. Do not use wheeled equipment over the system. A light track machine may be used with caution, avoiding crushing or shifting of pipe assembly. Divert surface runoff from the Effluent Disposal Area, (EDA). Finish grade to prevent surface ponding. Topsoil and seed system area to protect from erosion.

## 8.0 Dosing Distribution Guidance

**DOSING DESIGN CRITERIA:** Dosing volume must be set to deliver a maximum of **4 gallons per B43 Module** and **3 gallons per A42 Module** per dosing cycle. Head loss and drain back volume must be considered in choosing the pump size and force main diameter.

## 9.0 Pressure Distribution Guidance

Standard procedures for design of pressure distribution networks apply to the GSF filter. A minimum orifice size of 1/8 to 1/4 inch shall be maintained. A 1/4 inch diameter drain hole is required at the 6 o'clock position of each pressure lateral for drainage purposes. The lateral pipe network (*size per design and code*) is placed within a standard 4-inch perforated pipe. The perforation in the 4-inch outer pipe are set at the 4 and 8 o'clock position, the drilled orifices on the pressure pipe are set to spray at the 12 o'clock position directly to the top of the 4-inch perforated pipe as shown below.

FIGURE 18: PRESSURE PIPE PLACEMENT

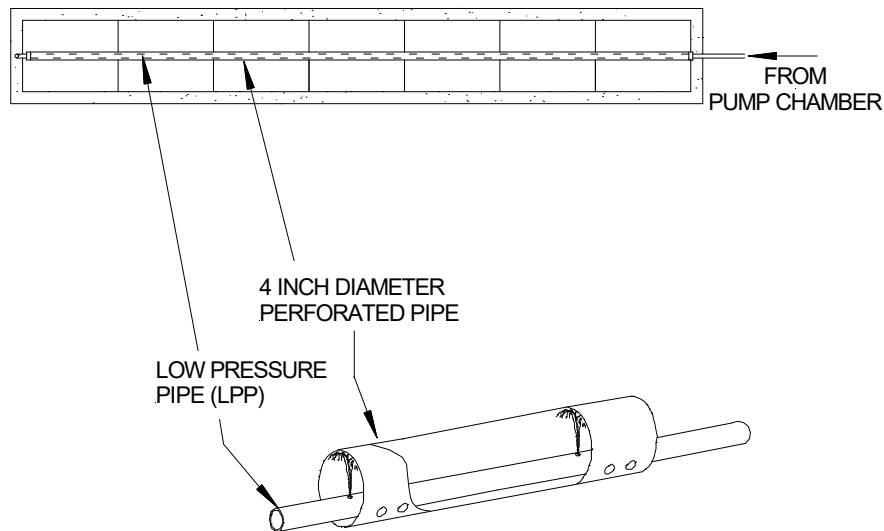

PRESSURE PIPE CROSS SECTION FOR ALL APPLICATIONS

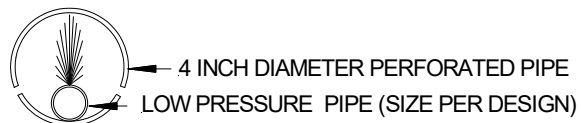



## 9.0 Pressure Distribution Guidance

---

FIGURE 19: CONTOURED TRENCH PRESSURE DISTRIBUTION

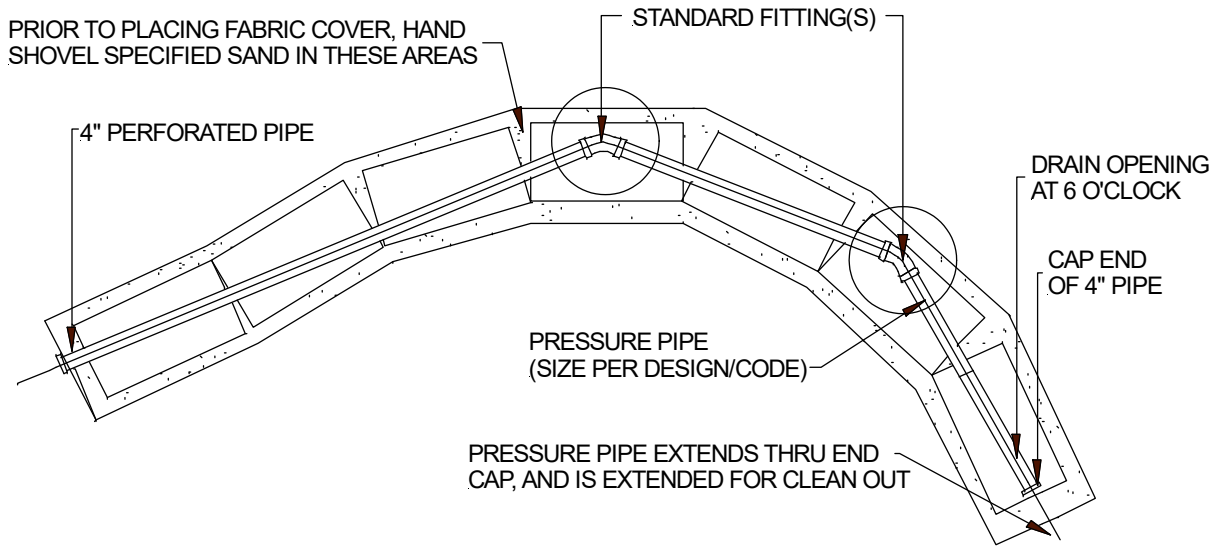

GSF Pressure Distribution trench placed on a contour or winding trenches to maintain horizontal separation distances.

## 10.0 System Ventilation

---

**10.1 SYSTEM VENTILATION:** Air vents are required on all absorption systems **with more than 18 inches of cover material** as measured from the top of the GSF module to finished grade. This will ensure proper aeration of the modules and sand filter. The GSF has aeration channels between the rows of GSF modules connecting to cuspatations within the GSF modules. Under normal operating conditions, only a fraction of the filter is in use. The unused channels remain open for intermittent peak flows and the transfer of air.

Home plumbing operates under negative pressure due to hot water heating the pipes and reducing the density of air in the house vent. As hot air rises and exits the home, it must be replaced by air from the GSF. To maintain this airflow and fully aerate the GSF system, it is important that air vents are located only on the distal end of the GSF pipe network.

**10.2 VENT PIPE FOR LOW PRESSURE DISTRIBUTION SYSTEMS:** If the system is a low pressure distribution system with greater than 18 inches of cover, ensure that the LPP clean outs are located in the vent for easy access.

# 10.0 System Ventilation

FIGURE 20: PRESSURE CLEAN OUT PRESSURE DOSED SYSTEMS

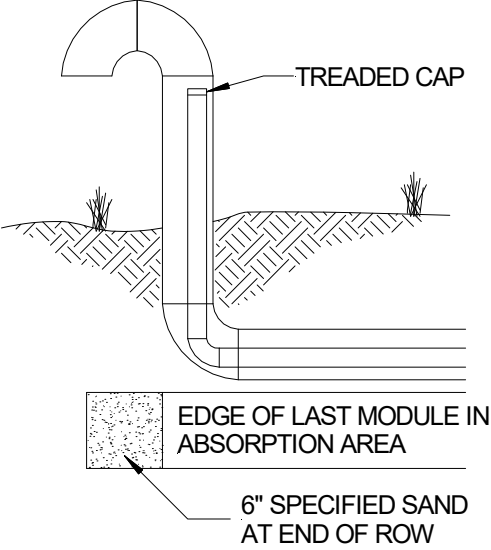

**10.3 VENTILATION PLACEMENT:** In a GSF system, the vent is usually a 4-inch diameter pipe extended to a convenient location behind shrubs, as shown in Figure 21. Corrugated pipe may be used. If using corrugated pipe, ensure that the pipe does not have any bends that will allow condensation to pond in the pipe. This may close off the vent line. The pipe must have an invert higher than the system so that it does not drain effluent.

FIGURE 21: GSF WITH 4" VENT EXTENDED TO CONVENIENT LOCATION

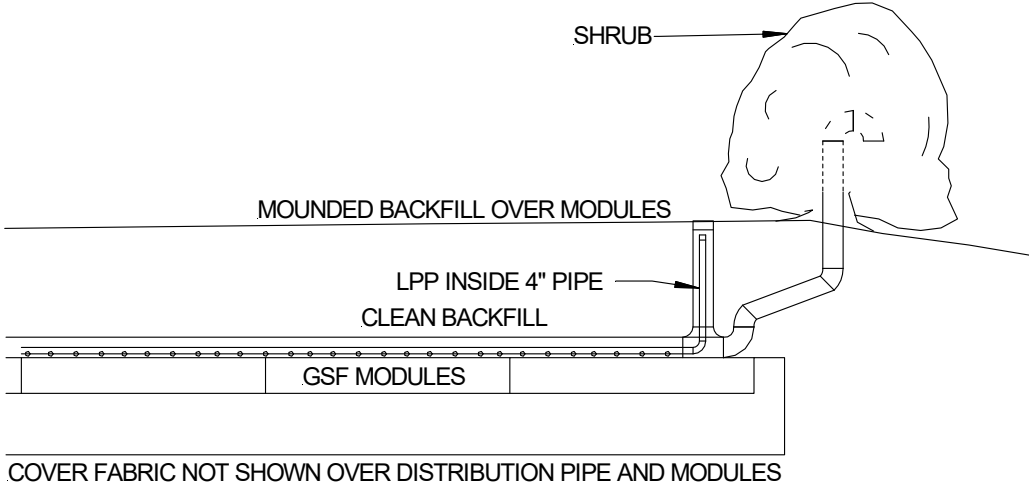

## 11.0 Treated Effluent Sampling Port Installation

---

### 11.1 OVERVIEW

1. Determine the location of the System Sampling Port within the system. We recommend that a minimum of three Sampling Collection Pipes are placed within the same row. One Sampling Collection Pipe under the first module, one under the last, and one in the middle of the row. Pressurized systems may use the valve and cleanout ports for sample tube access instead of the depicted Sampling Tube. Standard observation ports are also acceptable.

FIGURE 22: SYSTEM SAMPLING PORT LOCATIONS

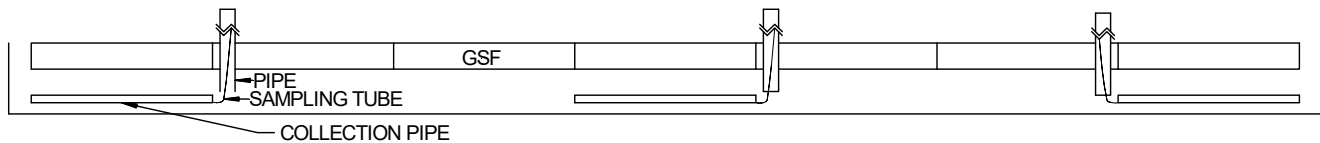

2. The System Sampling Port consists of:
  - a. Sampling Collection Pipe
  - b. Sampling Tube
  - c. Sampling Tube Storage Pipe
3. Carefully lay out the system area and boundaries.
4. Prepare the site. Excavate a trench to the design elevation for the system.

### 11.2 SAMPLING COLLECTION PIPE & SAMPLING TUBE INSTALLATION

1. In the excavated trench, place Specified Sand in a 3 inch lift and stabilize.
2. Place the three Collection Pipes level in the Trench, Bed or Mound under the location of the first, middle and last module of a row. The Sampling Collection Pipe should be centered underneath the GSF Module (Figure 2). **Keep the sampling tube out of the way and out of the trench.**
3. Place remaining Specified System Sand in the system area, filling the Collection Pipe with the Specified Sand. The height of Specified Sand should now be a minimum 12 inches high within the system area.

## 11.0 Treated Effluent Sampling Port Installation

---

4. Pull the Sampling Tube through the Sampling Tube which is installed on top of the Specified Sand Layer. It should be located at the outside edge of the proposed location of the GSF unit area to be sampled. The Sampling Tube Storage Pipe should be tall enough to make it to the surface.

FIGURE 23: INSTALLATION OF SAMPLING TUBE STORAGE PIPE

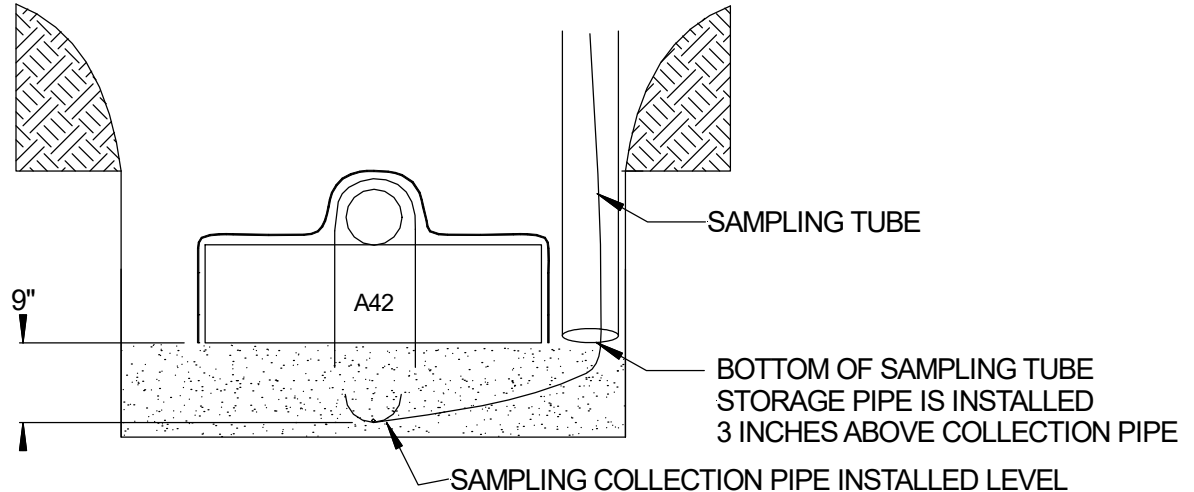

*Note: Separation distance from the bottom of the GSF module to the bottom of the Sampling Tube Collection Pipe must be a minimum of 9 inches.*

5. The stabilized Specified Sand height below the GSF module must be a minimum of 9 inches. A hand tamper is sufficient to stabilize the Specified Sand below the GSF modules.
6. Complete installation of the GSF system according to your plan and Design and Installation Manual.

# 12.0 GSF Inspection Check List

Geotextile Sand Filter, (GSF) Checklist				
Facility Owner:				
Facility Address:				
Installation Date: (MDY)				
Previous Inspection Date: (MDY)				
Date of Inspection: (MDY)				
Residential Number of Bedrooms:				
Is this a Commercial Design? If yes, what type:	Yes	No		
What is the estimated BOD5 and TSS strength?	BOD5	TSS	Comments	
Observation Port Location(s):	1	2	3	
Inspection Data, (complete all fields)				
Is daily flow within the system design flow? If no, explain:	Yes	No		
Does the owner verify the system use as described above? If no, explain:	Yes	No		
Septic tank last inspection date:	Date			
Inspected by:				
Septic tank last pumped date:				
Is pumping recommended?	Yes	No		
Condition of the soil absorption system: Wet, Dry, Firm, Soft, Vegetative, or Other. If Other, explain:	W	D	S	F V
Is there evidence of storm water flows or erosion over the septic system? If yes, explain:	Yes	No		

## 12.0 GSF Inspection Check List

Is there evidence of soil slump or compaction by traffic or other means in the vicinity of the soil absorption system? If yes, describe:	Yes	No	Comments
Is effluent visible through the observation port? If yes, describe the condition and the fluid level:	Yes	No	Comments
Is there a garbage disposal in the home?	Yes	No	Comments
Is a water softener connected to the system?	Yes	No	Comments
Are solids visible through the observation port? If yes, describe the condition and depth of solids:	Yes	No	Comments
Is there evidence of surcharging or effluent ponding in the D-Box? If yes, describe and measure:	Yes	No	Comments
Are the system vents in place?	Yes	No	Comments
Are they operational? If no, describe conditions and location:	Yes	No	
Describe any other pertinent issues:			

Inspected by:	
License Number:	
Date:	
Time:	
Print Name & Signature of Inspector:	
<p><b><i>I certify I have inspected the system at the above address, completed this report, and the information reported is true, accurate, and complete.</i></b></p>	



## **COMPANY HISTORY**

Established in 1970, Eljen Corporation created the world's first prefabricated drainage system for foundation drainage and erosion control applications. In the mid-1980s, we introduced our Geotextile Sand Filter products for the passive advanced treatment of onsite wastewater in both residential and commercial applications. Today, Eljen is a global leader in providing innovative products and solutions for protecting our environment and public health.

## **COMPANY PHILOSOPHY**

Eljen Corporation is committed to advancing the onsite industry through continuous development of innovative new products, delivering high quality products and services to our customers at the best price, and building lasting partnerships with our employees, suppliers, and customers.



90 Meadow Road, Windsor, CT 06095 • Tel: 800-444-1359 • Fax: 860-610-0427

**[www.eljen.com](http://www.eljen.com)**

