

# GSF IN-GROUND COMPONENT MANUAL

May 2018

Table of Contents	Page
I. INTRODUCTION AND SPECIFICATIONS .....	3
II. DEFINITIONS .....	11
III. DESCRIPTION AND PRINCIPLE OF OPERATION .....	11
IV. SOIL AND SITE REQUIREMENTS .....	13
V. COVER MATERIAL .....	13
VI. DESIGN.....	13
VII. SITE PREPARATION AND CONSTRUCTION .....	20
VIII. OPERATION, MAINTENANCE AND PERFORMANCE MONITORING .....	21
IX. REFERENCES .....	23
X. GSF IN-GROUND WORKSHEET .....	24
XI. EXAMPLE GSF IN-GROUND WORKSHEET .....	27
XII. PLAN SUBMITTAL AND INSTALLATION INSPECTION .....	30
XIII. POWTS INSPECTION REPORT .....	32

**Published by:  
Eljen Corporation  
125 McKee St.  
East Hartford, CT 06108**

**This component manual was produced exclusively by Eljen Corporation for use with Eljen GSF products. This manual is based upon the “In-Ground Soil Absorption Component Manual for Private Onsite Wastewater Treatment Systems” Ver. 2.0, October, 2012, by the State of Wisconsin, Department of Safety and Professional Services.**

**Eljen Corporation reserves the right to revise this component manual according to changes in regulations or Eljen GSF system installation instructions.**

I. INTRODUCTION AND SPECIFICATIONS

This Private Onsite Wastewater Treatment System (POWTS) component manual provides design, construction, inspection, operation, and maintenance specifications for an GSF system. However, these items must accompany a properly prepared and reviewed plan acceptable to the governing unit to help provide a system that can be installed and function properly. Violations of this manual constitute a violation of chs. SPS 383 and 384, Wis. Adm. Code. The GSF system must receive influent flows and loads less than or equal to those specified in Table 1. When designed, installed and maintained in accordance with this manual, the GSF system provides treatment and dispersal of domestic wastewater in conformance with ch. SPS 383 of the Wis. Adm. Code. Final effluent characteristics will comply with s. SPS 383.41, Wis. Adm. Code when inputs are within the range specified in Tables 1 to 3.

Note: Detailed plans and specifications must be developed, and submitted for review and approval by the governing unit having authority over the plan for the installation. Also, a Sanitary Permit must be obtained from the department or governmental unit having jurisdiction. See Section XII for more details.

Table 1 Influent Flows and Loads	
Design Wastewater flow (DWF)	≤ 5000 gal/day
Monthly average value of Fats, Oil and Grease (FOG)	≤ 30 mg/L
Monthly average value of five day Biochemical Oxygen Demand (BOD <sub>5</sub> )	≤ 220 mg/L
Monthly average value of Total Suspended Solids (TSS)	≤ 150 mg/L
Maximum Volume of a single dose to absorption component when pumps or siphons are employed in the design	A42 = 3 gallons/dose/unit B43 = 4 gallons/dose/unit
Design wastewater flow (DWF) from one and two-family dwellings	Based on s. SPS 383.43 (3), (4), or (5), Wis. Adm. Code
Design wastewater flow (DWF) from public facilities	≥ 150% of estimated daily wastewater flow in accordance with Table 4 of this manual or s. SPS 383.43 (6), Wis. Adm. Code
Wastewater particle size	≤ 1/8 inch
Distribution cell area per orifice when pressure distribution is used	≤ 24 ft <sup>2</sup> B43 or ≤ 20 ft <sup>2</sup> A42

Table 2 SIZE AND ORIENTATION	
Distribution cell width (A) <sup>a</sup>	≤ 6 feet = Number of product rows x product width. Product width is shown in Table 2b; two rows of A42s can achieve a 6 foot width. Units may also use up 18 inches of sand on each side of the product to achieve a 6 foot width. For instance, B43 units used with 18 inches of specified sand can achieve a 6 foot width; refer to Table 2c for configurations
Required # of Products	≥ Design wastewater flow rate ÷ design loading rate of the fill material ÷ square footage of product (shown in Table 2b), round up to nearest whole number; Min 5 B43 units per bedroom or 6 A42 units per bedroom in residential applications
Distribution cell length (B) <sup>a</sup>	Multiple # of GSF units x 4 ft + 1 ft
Orientation	Longest dimension parallel to surface grade contours on sloping sites.
Deflection of distribution cell on concave slopes	≤ 10%
Basal area	Design wastewater flow ÷ soil application rate for the in situ soil at the infiltrative surface or a lower horizon if the lower horizon adversely affects the dispersal of wastewater in accordance with s. SPS 383.44 (4) (a) and (c) , Wis. Adm. Code
Soil Application Rate	The designer may use Effluent #2 in accordance with s. SPS Table 383.44-1 and 383.44-2, Wis. Adm. Code

Table 2b APPROVED PRODUCT MODEL NUMBERS AND DIMENSIONS				
Product	Square Footage	Product Width	Product Length	Product Height
A42	12 square feet per unit	36"	48"	7"
B43	16 square feet per unit	48"	48"	7"

Table 2c APPROVED PRODUCT INSTALLATIONS AND SQUARE FOOTAGE				
Product	Square Footage	Installation Width	Installation Length	Install Height
A42	12 square feet per unit	36"	48"	19"
	16 square feet per unit	48"	48"	19"
	20 square feet per unit	60"	48"	19"
B43	16 square feet per unit	48"	48"	19"
	20 square feet per unit	60"	48"	19"
	24 square feet per unit	72"	48"	19"

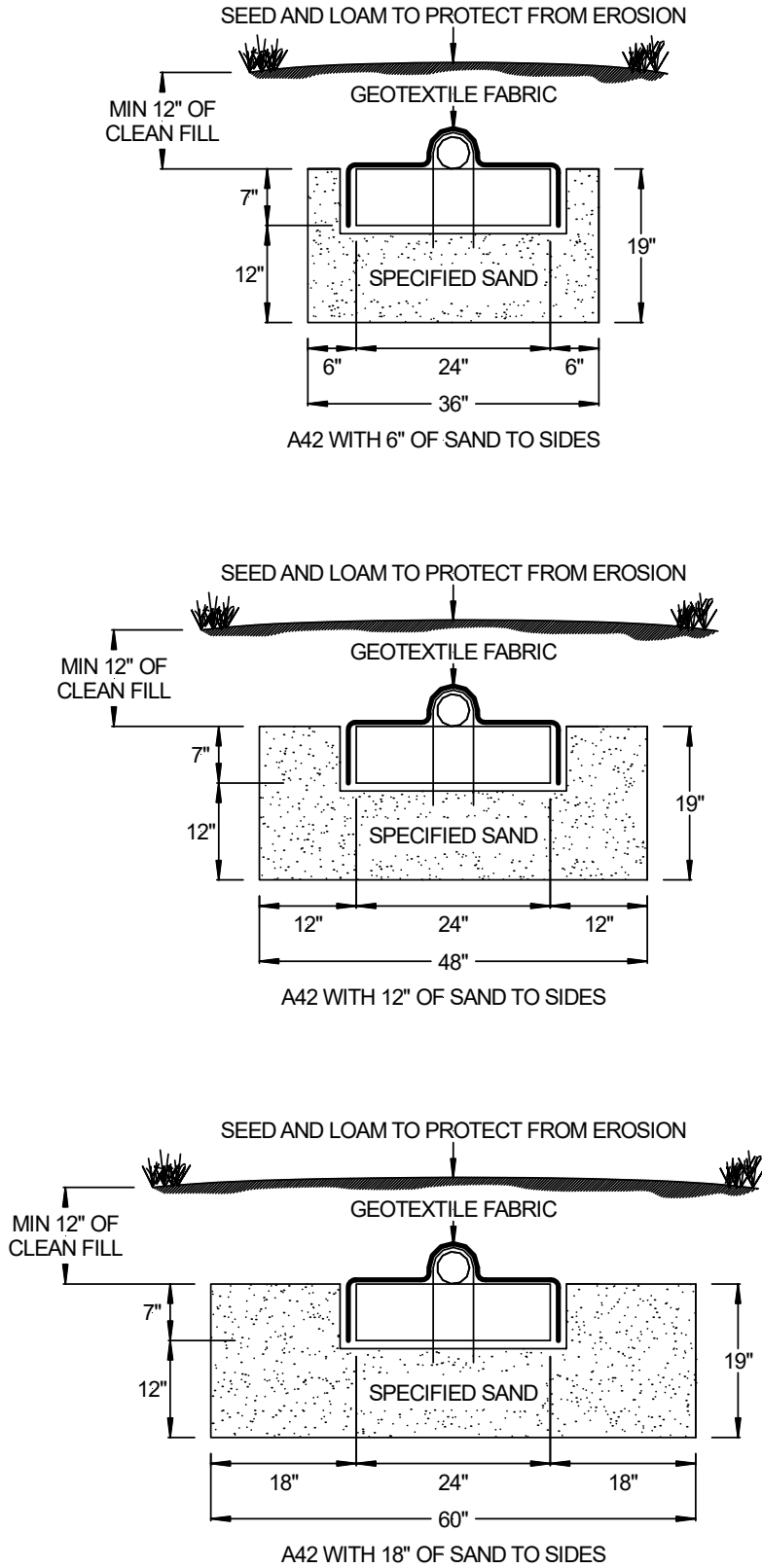

Figure 1. A42 Single Lateral In-Ground Cross Sections

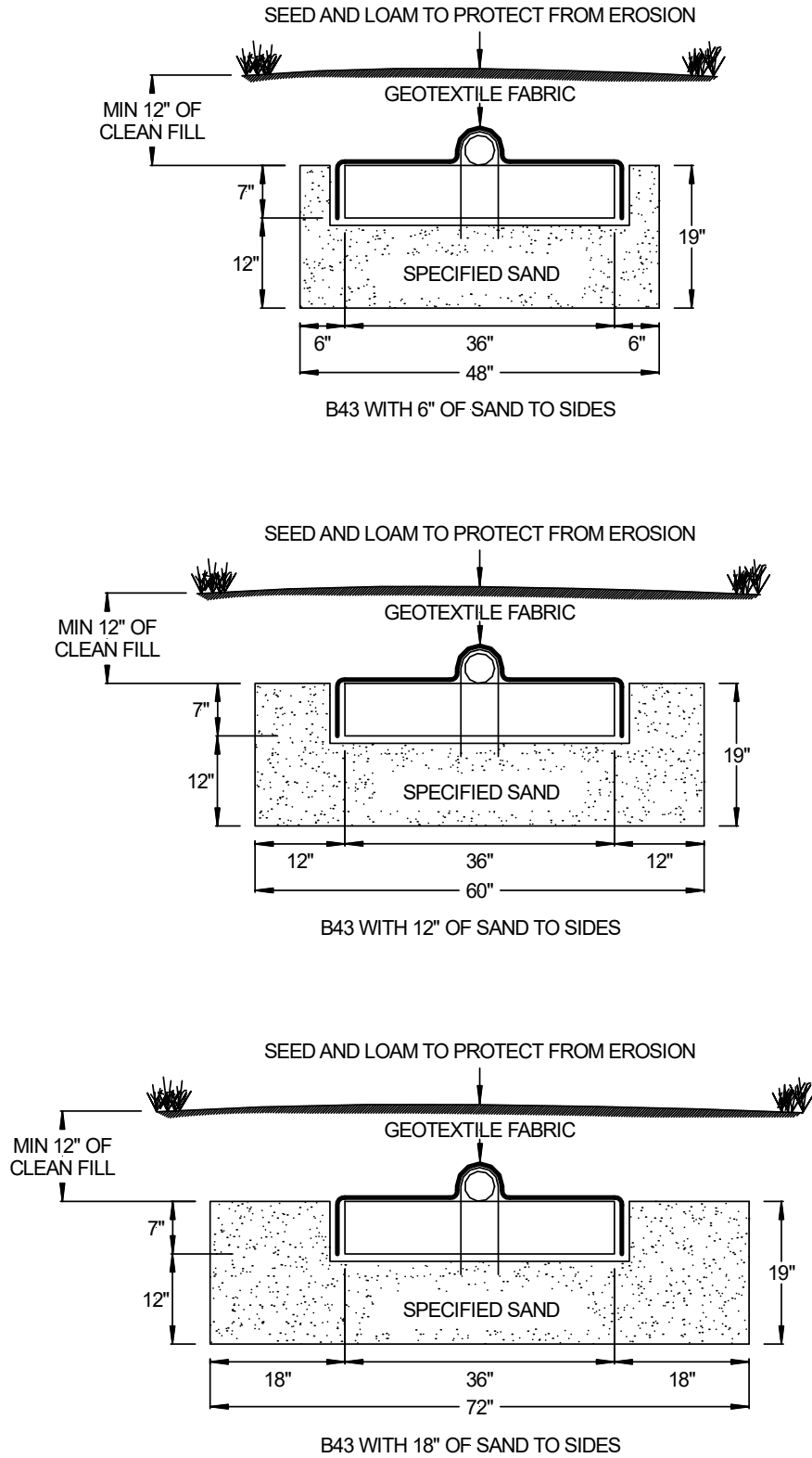

Figure 2. B43 Single Lateral In-Ground Cross Sections

Table 3 OTHER SPECIFICATIONS	
Slope of in situ soil	≤ 25% in area of component
Vertical separation between bottom of GSF unit and seasonal saturation defined by redoximorphic features,	≥ Equal to depth required by s. SPS 383 Table 383.44-3, Wis. Adm. Code
Bottom of distribution cell	Level
Horizontal separation between distribution cells	≥ 3 ft.
Piping material in the distribution system	Meets requirements of s. SPS 384.30 (2), Wis. Adm. Code for its intended use
Piping material for observation, vent, and	Meets requirements of s. 384.30 Table 384.30-1, Wis. Adm. Code
Slope of gravity flow perforated distribution lateral piping	≤ 4 inches per 100 feet away from distribution boxes, drop boxes or header
Location of gravity flow perforated distribution pipe in distribution cell	Centered over the GSF unit
Location of GSF Units	<p>Located as follows:</p> <p>Single A42 Line 12 sf/unit – Units are centered in a 3 foot width trench, 6 inches of sand on either side</p> <p>Single A42 Line 16 sf/unit – Units are centered in a 4 foot width trench, 12 inches of sand on either side</p> <p>Single A42 Line 20 sf/unit – Units are centered in a 5 foot width trench, 18 inches of sand on either side</p> <p>Dual A42 System – Units have 6 inches of sand from sidewall and 1 foot of sand in between units</p> <p>Single B43 Line 16 sf/unit – Units are centered in a 4 foot width trench, 6 inches of sand on either side</p> <p>Single B43 Line 20 sf/unit – Units are centered in a 5 foot width trench, 12 inches of sand on either side</p> <p>Single B43 Line 24 sf/unit – Units are centered in a 6 foot width trench, 18 inches of sand on either side</p>

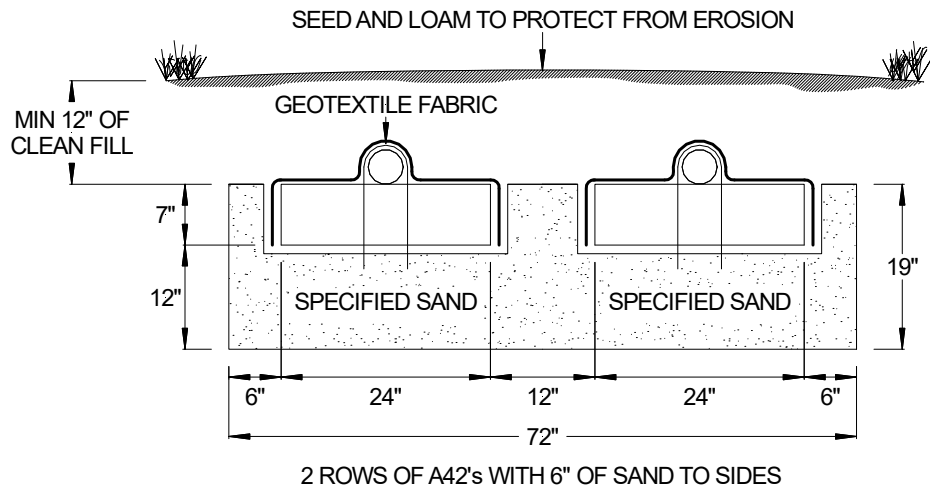

Figure 3. A42 Dual Lateral In-Ground Cross Section

Table 3 OTHER SPECIFICATIONS (continued)	
Length of distribution pipe for components using gravity flow distribution	≥ Equal to length of distribution cell minus 2 feet
Distance between distribution pipe end orifice and end of distribution cell for components using gravity flow distribution	≤ 2 feet
Length of GSF system row	Multiple # of GSF units x 4 ft
Number of observation pipes per distribution cell	≥ 2
Location of observation pipes	For flexibility in pipe location, see VII. C. 5.
Design and installation of observation pipes	<ol style="list-style-type: none"> <li>1. Have an open bottom</li> <li>2. Have a nominal pipe size of 4 inches</li> <li>3. The lower 19 inches slotted</li> <li>4. Slots are ≥ 1/4" and ≤ 1/2" in width and located on opposite sides</li> <li>5. Anchored in a manner that will prevent the pipe from being pulled out</li> <li>6. Extend from the infiltrative surface up to or above finish grade</li> <li>7. Terminate with a removable watertight cap, or</li> <li>8. Terminate with a vent cap if ≥ 12 inches above finish grade</li> </ol>



Table 3  
OTHER SPECIFICATIONS  
(continued)

Effluent application to GSF system	<ol style="list-style-type: none"> <li>1. If DWF &lt; 1500 gpd, effluent may be applied by gravity flow, dosed to distribution cell or distribution box, then applied by gravity flow to the distribution cell, or by use of pressure distribution, unless pressure distribution is required in accordance with s. SPS 383.44 (5) (b)</li> <li>2. If DWF ≥ 1500 gpd, effluent must be dosed to distribution cell or distribution box, then applied by gravity flow to the distribution cell, or by use of pressure distribution, unless pressure distribution is required in accordance with s. SPS 383.44 (5) (b) , Wis. Adm. Code</li> </ol>
Septic tank effluent pump system	Meets requirements of s. SPS 384.10, Wis. Adm. Code and this manual
Dose tank or compartment volume employing one pump	<p>≥ Volume of a single dose + reserve capacity<sup>a</sup> + drain back volume<sup>b</sup> + (6 inches x average gal/inch of tank)<sup>c</sup></p> <p>Notes: a: Reserve capacity ≥ the estimated daily flow.  b: Drain back volume ≥ volume of wastewater that will drain into the dose tank from the distribution cell.  c: Four inches of this dimension ≥ vertical distance from pump intake to bottom of tank. Two inches of this dimension ≥ vertical distance between pump on elevation and high water alarm activation elevation.</p>
Max bury depth	There is no max bury depth on this product.

Table 3 OTHER SPECIFICATIONS (continued)	
Dose tank or compartment volume employing duplex pumps	<p><math>\geq</math> Volume of a single dose + drain back volume<sup>a</sup> + (6 inches x average gal/inch of tank)<sup>b</sup></p> <p>Notes: a: Drain back volume <math>\geq</math> volume of wastewater that will drain into the dose tank from the force main. b: Four inches of this dimension <math>\geq</math> vertical distance from pump intake to bottom of tank. Two inches of this dimension <math>\geq</math> vertical distance between pump on elevation and high water alarm activation elevation.</p>
Siphon tank or compartment volume	$\geq$ What is required to accommodate volumes necessary to provide dosing as specified in this manual
Distribution network for pressurized distribution systems.	By use of pressure distribution network conforming with the sizing methods of either Small Scale Waste Management Project publication 9.6, entitled "Design of Pressure Distribution Networks for Septic Tank – Soil Absorption Systems" or Dept. of Safety and Professional Services publications SBD-10573-P or SBD-10706-P, entitled Pressure Distribution Component Manual for Private Onsite Wastewater Treatment Systems".
Vent pipes installed in the GSF system	<ol style="list-style-type: none"> <li>1. Connect to a gravity flow distribution lateral by the use of a fitting</li> <li>2. Have a nominal pipe size of 4 inches</li> <li>3. Extend from the distribution lateral <math>\geq</math> 12 inches above finish grade</li> <li>4. Terminate in a manner that will allow a free flow of air between the distribution lateral and the atmosphere</li> <li>5. The vent opening port is downward</li> <li>6. Required for systems with <math>\geq</math> 18 inches of cover.</li> </ol>
Combination observation/vent pipes installed in a GSF system	<p>Meets all of the requirements of observation pipes with the following exceptions:</p> <ol style="list-style-type: none"> <li>1. Have a minimum 4 inch pipe connection to a distribution lateral</li> <li>2. Extend from the infiltrative surface <math>\geq</math> 12 inches above finish grade</li> <li>3. Terminate in a manner that will allow a free flow of air between the distribution lateral and the atmosphere</li> <li>4. The vent opening port is downward</li> </ol>
Cover material over the geotextile fabric	Soil that will provide frost protection, prevent erosion and excess precipitation or runoff infiltration and allow air to enter the distribution cell
Installation inspection	In accordance with ch. SPS 383, Wis. Adm. Code
Management	In accordance with ch. SPS 383, Wis. Adm. Code and this manual

## II. DEFINITIONS

Definitions not found in this section, are located in ch. SPS 381 of the Wisconsin Administrative Code or the terms use the standard dictionary definition.

- A. A42 is a 24" wide by 48" long and 7" high unit made of cuspated core and geotextile fabric.
- B. B43 is a 36" wide by 48" long and 7" high unit made of cuspated core and geotextile fabric.
- C. "Product" means one GSF unit (A42 or B43), manufactured by Eljen Corporation.
- D. "Septic tank effluent pump system" means a septic tank which has a pump installed in the tank that will pump effluent from the clear zone.
- E. "Site plan" means a scaled or completely dimensioned drawing, drafted by hand or computer aided technology, presented in a permanent form that shows the relative locations of setback encumbrances to a regulated object. The site plan also includes a reference to north and the permanent vertical and horizontal reference point or benchmark.

## III. DESCRIPTION AND PRINCIPLE OF OPERATION

POWTS in-ground component operation is a two-stage process involving both wastewater treatment and dispersal. Treatment is accomplished predominately by physical and biochemical processes within the product and in situ soil. The physical characteristics of the influent wastewater, influent loading rate, temperature, and the nature of the receiving fill material and in situ soil affect these processes.

Physical entrapment, increased retention time, and conversion of pollutants in the wastewater are important treatment objectives accomplished under unsaturated conditions. Pathogens contained in the wastewater are eventually deactivated through filtering, retention, and absorption by in situ soil.

Dispersal is primarily affected by the depth of the unsaturated receiving soil, the soil's hydraulic conductivity, influent application rate, land slope and the area available for dispersal.

The in-ground GSF System consists of a distribution cell and cover material. Influent is dispersed into the GSF unit where it flows through the system and undergoes biological, chemical and physical treatment and then passes into the underlying soil for further treatment and dispersal to the environment.

Cover material consisting of material that provides erosion protection, a barrier to excess precipitation infiltration, and allows gas exchange. See Figures 1 & 2.

The in situ soil serves within the dispersal zone and provides for final dispersal of the effluent.

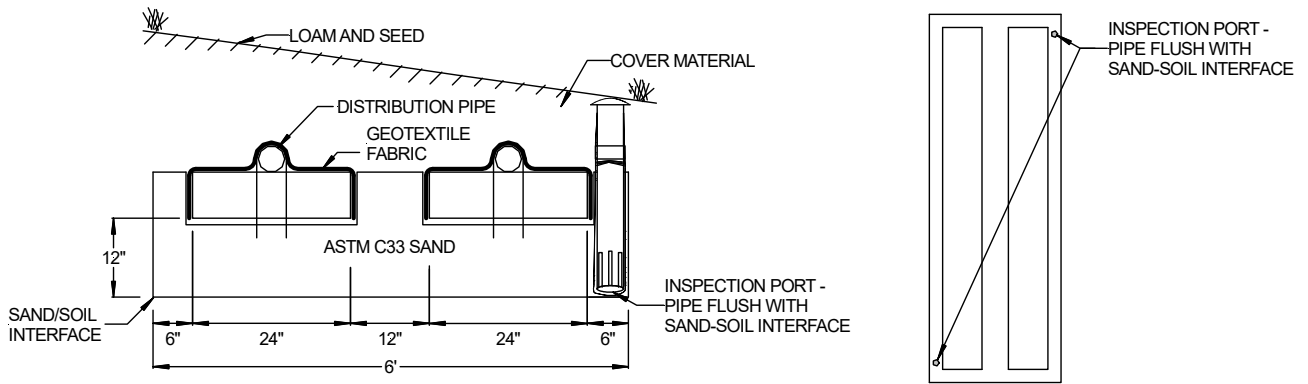

\*All inspection ports require anchoring, see the Observation Port section for more info.

Figure 4. A cross section of a 2 rows of A42 modules

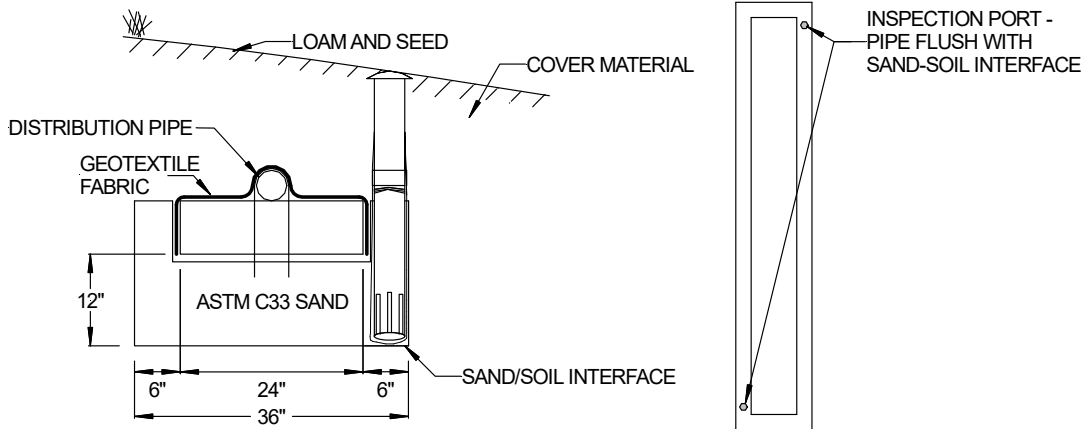

\*All inspection ports require anchoring, see the Observation Port section for more info.

Figure 5. A cross-section of an in-ground A42 GSF System with a single lateral

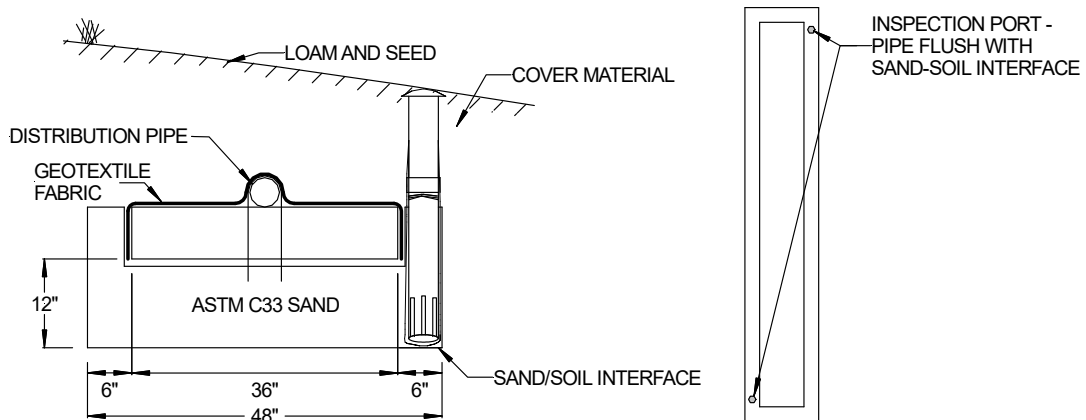

\*All inspection ports require anchoring, see the Observation Port section for more info.

Figure 6. A cross-section of an in-ground B43 GSF System with a single lateral

#### IV. SOIL AND SITE REQUIREMENTS

Every GSF in-ground design is ultimately matched to the given soil and site.

The design approach presented in this manual is based on criteria that all applied wastewater is successfully transported away from the system, that it will not affect subsequent wastewater additions, and that the effluent is ultimately treated.

- A. Minimum Soil Depth Requirements - The minimum soil factors required for successful in-ground GSF system performance are listed in the introduction and specification section of this manual.

Soil evaluations must be in accordance with ch. SPS 385 of the Wis. Adm. Code. In addition, soil application rates and depths must be in accordance with ch. SPS 383 of the Wis. Adm. Code.

- B. Other Site Considerations -

1. In-ground GSF location - In open areas, exposure to sun and wind increases the assistance of evaporation and transpiration in the dispersal of the wastewater.
2. Sites with trees and large boulders - Generally, sites with large trees, numerous smaller trees or large boulders are less desirable for installing a in-ground system because of difficulty in preparing the distribution cell. Areas that are occupied with rock fragments, tree roots, stumps and boulders reduce the amount of soil available for proper treatment. If no other site is available, trees in the distribution cell must be removed.
3. Setback distances - The setbacks specified in ch. SPS 383, Wis. Adm. Code for soil subsurface treatment/dispersal component apply to in-ground systems. The distances are measured from the edge of the distribution cell area.

#### V. COVER MATERIAL

The cover material is a soil that will allow air exchange while promoting plant growth. The gas exchange will increase the treatment performance of the system by providing oxygen to the wastewater to help ensure aerobic conditions in the system. The plant growth will provide frost protection in the winter season. Clays may not be used for cover material, as they will restrict oxygen transfer. Often, excavated soil from the site can be used.

#### VI. DESIGN

- A. Location, Size and Shape

Placement, sizing and geometry of the distribution cell must be in accordance with this component manual.

- B. Component Design

Design of the GSF system is based upon the design wastewater flow and the soil characteristics. It must be sized such that it can accept the daily wastewater flow without causing surface seepage or groundwater pollution. Consequently, the surface area of dispersal zone, which is the in situ soil area beneath the component, must be sufficiently large enough to absorb the applied effluent into the

underlying soil. The GSF must also be designed to avoid encroachment of the water table into the required minimum unsaturated zone.

Design of the GSF includes the following three steps: (A) calculating design wastewater flow, (B) calculating soil infiltration area, and (C) design of the distribution cell. Each step is discussed below.

Step A. Design Wastewater Flow Calculations

One and two-family dwellings. Distribution cell size for one and two-family dwelling application is determined by calculating the design wastewater flow (DWF). To calculate DWF use Group 1, 2 or 3. Group 1 is for combined wastewater flows, which consist of blackwater, clearwater and graywater. Group 2 is for only clearwater and graywater. Group 3 is for blackwater only.

Group 1 Combined wastewater DWF = 150 gal/day/bedroom	Group 2 Clearwater & Graywater DWF = 90 gal/day/bedroom	Group 3 Blackwater DWF = 60 gal/day/bedroom
---	---	---

Public Facilities. Distribution cell size for public facilities application is determined by calculating the DWF using Formula 2. Only facilities identified in Table 4 are included in this manual. Estimated daily wastewater flows are determined in accordance with Table 4 or s. 383.43(6), Wis. Adm. Code. Many commercial facilities have high BOD5, TSS and FOG (fats, oils and grease), which must be pretreated in order to bring their values down to an acceptable range before entering into the GSF system described in this manual.

Formula 1

$$\text{DWF} = \text{Sum of each estimated wastewater flow per source per day} \times 1.5$$

Where 1.5 = Conversion factor to convert estimated wastewater flow to design wastewater flow

Table 4  
Public Facility Wastewater Flows

Source	Unit	Estimated Wastewater Flow (gpd)
Apartment or Condominium	Bedroom	100
Assembly hall (no kitchen)	Person (10 sq. ft./person)	1.3
Bar or cocktail lounge (no meals served)	Patron (10 sq. ft./patron)	4
Bar or cocktail lounge* (w/meals – all paper service)	Patron (10 sq. ft./patron)	8
Beauty salon	Station	90
Bowling alley	Bowling lane	80
Bowling alley (with bar)	Bowling lane	150
Camp, day and night	Person	25
Camp, day use only (no meals served)	Person	10
Campground or Camping Resort	Space, with sewer connection and/or service building	30
Campground sanitary dump station	Camping unit or RV served	25
Catch basin	Basin	65
Church (no kitchen)	Person	2
Church* (with kitchen)	Person	5
Dance hall	Person (10 sq. ft./person)	2
Day care facility (no meals prepared)	Child	12
Day care facility* (with meal preparation)	Child	16
Dining hall* (kitchen waste only without dishwasher and/or food waste grinder)	Meal served	2
Dining hall* (toilet and kitchen waste without dishwasher and/or food waste grinder)	Meal served	5
Dining hall* (toilet and kitchen waste with dishwasher and/or food waste grinder)	Meal served	7
Drive-in restaurant* (all paper service with inside seating)	Patron seating space	10
Drive-in restaurant* (all paper service without inside seating)	Vehicle space	10
Drive-in theater	Vehicle space	3
Employees (total all shifts)	Employee	13
Floor drain (not discharging to catch basin)	Drain	25
Gas station / convenience store	Patron (minimum 500 patrons)	3
Gas station (with service bay)		
Patron	Patron	3
Service bay	Service bay	50
Hospital*	Bed space	135
Hotel, motel or tourist rooming house	Room	65
Medical office building		
Doctors, nurses, medical staff	Person	50
Office personnel	Person	13
Patients	Person	6.5
Migrant labor camp (central bathhouse)	Employee	20
Mobile Home (Manufactured home) (served by its own POWTS)	Bedroom	100
Mobile home park	Mobile home site	200

\* = May be high strength waste

Table 4  
Public Facility Wastewater Flows  
(continued)

Source	Unit	Estimated Wastewater Flow (gpd)
Nursing, Rest Home, Community Based Residential Facility	Bed space	65
Outdoor sport facilities (toilet waste only)	Patron	3.5
Parks (toilets waste only)	Patron (75 patrons/acre)	3.5
Parks (toilets and showers)	Patron (75 patrons/acre)	6.5
Public shower facility	Shower taken	10
Restaurant*, 24-hr. (dishwasher and/or food waste grinder only)	Patron seating space	4
Restaurant*, 24-hr. (kitchen waste only without dishwasher and/or food waste grinder)	Patron seating space	12
Restaurant, 24-hr. (toilet waste)	Patron seating space	28
Restaurant*, 24-hr. (toilet and kitchen waste without dishwasher and/or food waste grinder)	Patron seating space	40
Restaurant*, 24-hr. (toilet and kitchen waste with dishwasher and/or food waste grinder)	Patron seating space	44
Restaurant* (dishwasher and/or food waste grinder only)	Patron seating space	2
Restaurant* (kitchen waste only without dishwasher and/or food waste grinder)	Patron seating space	6
Restaurant (toilet waste)	Patron seating space	14
Restaurant* (toilet and kitchen waste without dishwasher and/or food waste grinder)	Patron seating space	20
Restaurant* (toilet and kitchen waste with dishwasher and/or food waste grinder)	Patron seating space	22
Retail store	Patron (70% of total retail area ÷ 30 sq. ft. per patron)	1
School* (with meals and showers)	Classroom (25 students/classroom)	500
School* (with meals or showers)	Classroom (25 students/classroom)	400
School (without meals or showers)	Classroom (25 students/classroom)	300
Self-service laundry (toilet waste only)	Clothes washer	33
Self-service laundry (with only residential clothes washers)	Clothes washer	200
Swimming pool bathhouse	Patron	6.5

\* = May be high strength waste



### Step B. Sizing of the Distribution Cell Area

The required distribution cell area is based on the design wastewater flow and the slowest soil application rate of the in situ soil at the infiltrative surface or a lower horizon adversely affects the dispersal of wastewater in accordance with s. SPS 383.44 (4) (a) and (c). Wastewater application rates to the soil are found in ch. SPS 383, Table 383.44-2, Wisconsin Admin Code.

Using the above information, the required distribution cell area can be determined using the following formula:

Area = design wastewater flow ÷ application rate of the in situ soil in accordance with s. SPS 383.44 (4) (a) and (c), Wisconsin Administrative Code. Note: This area may include the area of more than one distribution cell.

### Step C. Component Configuration

The maximum distribution cell width is six feet. The maximum length and width of the distribution cell is dependent on setback requirements of s. SPS Table 383.43-1, Wisconsin Administrative Code, and the soil evaluations results.

Where possible, on sloping sites the distribution cell is aligned with its longest dimension parallel to the land surface contours so as not to concentrate the effluent into a small area as it moves vertically and horizontally down slope.

#### Distribution Cell Height

The distribution cell height provides effluent treatment and support of the piping within the distribution cell. The height of the product is seven inches high. With the ASTM C33 sand it is a minimum 19 inches high which provides a minimum space of 12 inches beneath the unit. See Figure 7.

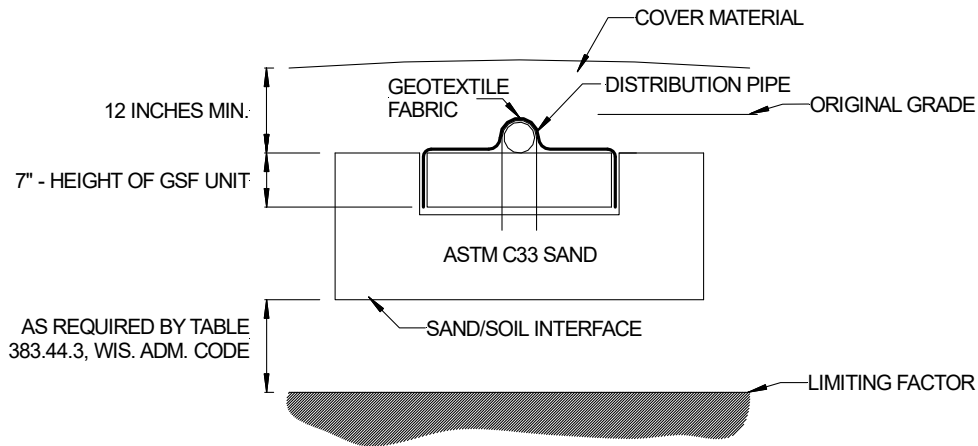

Figure 7. Height of system using GSF Units

### Cover Material

A minimum of 12 inches of cover material must be placed over the top of the unit. Finished grade of the cover material must be at or above the surrounding land surface elevation. Depressional areas over the distribution cell that collect and retain surface water runoff must be avoided.

### Distribution Network and Dosing Component

The effluent application to the distribution cell may be by gravity or pressure. Distribution boxes or drop boxes may be used to distribute effluent to gravity feed distribution cells. Distribution piping for a gravity component has a nominal inside diameter of 4 inches. The distribution header is non-perforated pipe. The slope of gravity flow perforated distribution piping is less than or equal to 4 inches per 100 feet away from distribution boxes, drop boxes or header. When a drop box design wastewater flow per day by is used, the invert of the drop box overflow pipe must be at least 4 inches lower than the invert of the treatment tank outlet or force main connection.

The design and installation of distribution boxes must be watertight and capable of providing a means of providing equal distribution of effluent to each distribution cell. Drop boxes must be watertight and capable of distributing effluent to another distribution cell.

Components that are designed to receive a DWF greater than 1500 gal/day, dose the effluent to the distribution cell by means of a pump or siphon. The dose chamber shall contain sufficient volume to dose the distribution cell as required by its system design, retain drain back volume, contain a one day reserve zone, provide a minimum 2 inch separation between alarm activation and pump-on activation, and allow for protection of the pump from solids.

Drain back volumes can be calculated based on values listed in Table 5.

Table 5 VOID VOLUME FOR VARIOUS DIAMETER PIPES BASED ON NOMINAL I.D. <sup>a</sup>	
Nominal Pipe Size	Gallons per Foot
1-1/4	0.064
1-1/2	0.092
2	0.163
3	0.367
4	0.65
6	1.469

Note a: Table is based on -  $\pi(d/2)^2 \times 12''/\text{ft} \div 231 \text{ cu.in./cu.ft.}$

Where: d = nominal pipe size in inches

A reserve capacity is required on a system with only one pump. The reserve volume must be equal to or greater than the estimated daily wastewater flow. Reserve capacity may be calculated using 100 gallons per bedroom per day for one and two family residences or the values computed by using Table 4.

The dose volume shall be included in the sizing of the dose chamber. (Volume of a septic tank effluent pump system is determined by department plumbing product approval.)

The pump alarm activation point must be at least 2 inches above the pump activation point.

Allow “dead” space below the pump intake to permit settling of solids in the dose chamber. This can be accomplished by placing the pump on concrete blocks or other material that can form a pedestal.

The pump manufacturer’s requirements shall be followed. This may include the “pump off” switch being located high enough to allow for complete immersion of the pump in the dose chamber.

GSF distribution pipe tops are at or below the original grade. GSF units are placed directly on top of the ASTM C33 sand. See Figures 1, 2 and 3 for proper positioning of the units in the trench.

### Observation Pipes

Observation pipes are installed in each distribution cell and are provided with a means of anchoring to prevent them from being lifted up. Acceptable methods include placing a bar through the observation pipe as depicted below and using a flange fitting at the base of the observation port. Observation pipes extend from the sand/soil interface to a point at or above finish grade. The portion of the observation pipe below the distribution pipe is slotted while the portion above the unit is solid wall. All observation piping has a nominal pipe size of 4 inches. See Figure 8.

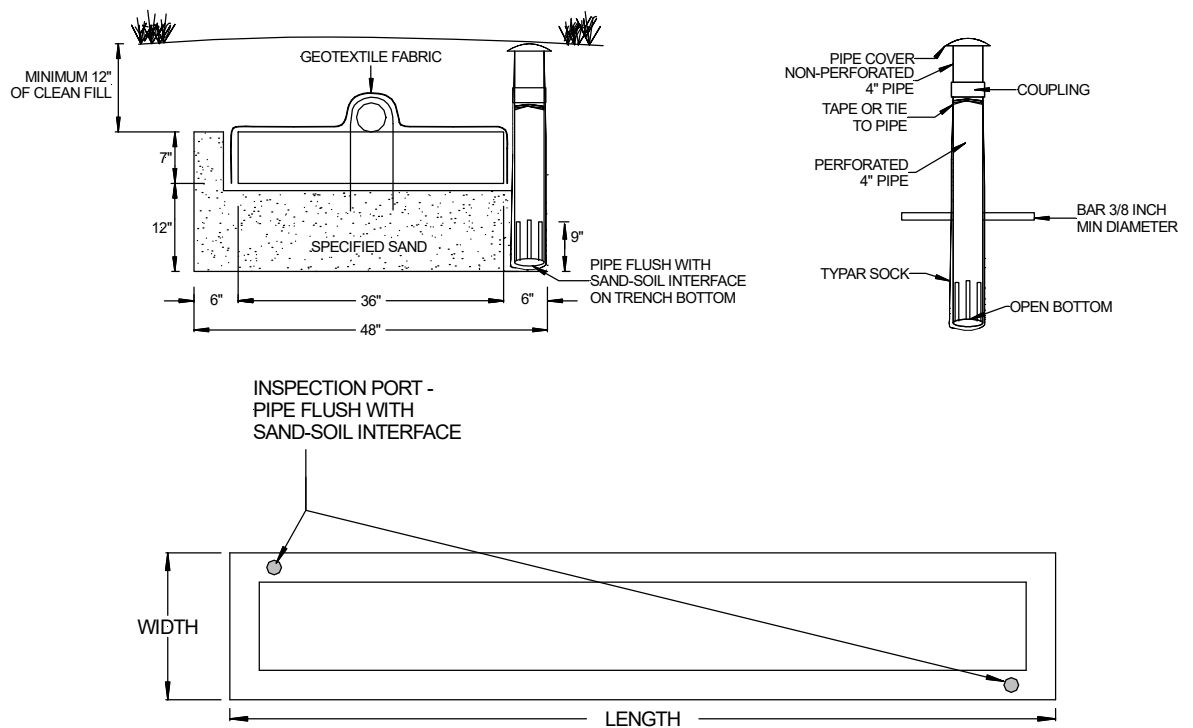

Figure 8. Observation pipes

### Vent Pipes

Vent pipes, if installed, connect to the upper half of the gravity flow distribution laterals and extend up to at least 12 inches above finish grade. Vent pipes terminate with the vent opening facing downward by the means of a vent cap or fittings. Vent caps must allow a free flow of air between the distribution lateral and the atmosphere. All vent pipes has a nominal pipe size of 4 inches.

When a vent pipe is connected to an observation pipe, the point of connection shall be made at a point above the module and terminate as required for vent pipes.

An observation pipe may serve as a combination observation/vent pipe providing it terminates in the same manner as required for vent pipes. See Figure 9.

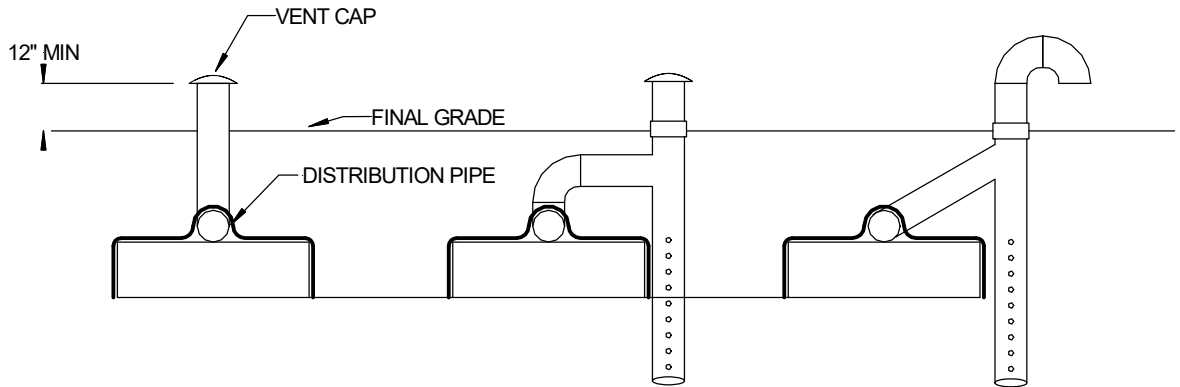

Figure 9. Vent and combination observation/vent pipes

## VII. SITE PREPARATION AND CONSTRUCTION

Procedures used in the construction of a in-ground GSF system are just as critical as the design of the component. A good design with poor construction results in system failure. It is emphasized that the soil only be worked when it is not frozen and the moisture content is low to avoid compaction and smearing. Consequently, installations are to be made only when the soil is dry enough to prevent compaction and smearing of the infiltrative surface. The construction plan to be followed includes:

A. Equipment - Proper equipment is essential. Track type equipment that will not compact the infiltrative surface. Minimize foot traffic and avoid equipment traffic over the infiltrative surface.

B. Sanitary Permit - Prior to the construction of the system, a sanitary permit, obtained for the installation must be posted in a clearly visible location on the site. Arrangements for inspection(s) must also be made with the department or governmental unit issuing the sanitary permit.

### C. Construction Procedures

1. Check the moisture content and condition of the soil. If the soil at the infiltrative surface can be rolled into a 1/4-inch wire, the site is too wet, smearing and compaction will result, thus reducing the infiltrative capacity of the soil. If the site is too wet, do not proceed until it dries out. If the soil at or below the infiltrative surface is frozen, do not proceed.
2. Set up a construction level or similar device and determine all relative elevations in relationship to the bench mark. It is necessary to determine the bottom elevation of the distribution cell, land surface contour lines, and approximate component elevations critical to the installation.
3. Lay out the absorption area within the designated area. Where possible lay out the absorption areas(s) on the site so that the distribution cell runs parallel with the land surface contours.

Reference stakes offset from the corner stakes are recommended in case corner stakes are disturbed during construction.

4. Excavate the distribution cell(s) to the correct bottom elevation(s) taking care not to smear the infiltrative surface. If the infiltrative surface or sidewalls are smeared, loosen it with the use of a rake or similar device.
5. Install observation pipes with the bottom 19 inches of the pipe slotted. Installation of the observation pipe includes a suitable means of anchoring so the pipes are not dislodged during inspections. Observation pipes will be installed in each distribution cell so as to be representative of a cell's hydraulic performance. Flexibility in location allows that observation pipes: be located such that there are a minimum of two installed in each dispersal cell at opposite ends from one another; be located near the dispersal cell ends; placed alongside the GSF unit; and be installed at an elevation to view the sand soil interface.
6. Install the GSF units in accordance with the manufacturer's installation instructions.
  - a. Place ASTM C33 sand in two 6 inch lifts into the distribution cell and stabilize the sand.
  - b. Place the GSF Modules end to end on top of the specified sand along their 4-foot length, PAINTED STRIPE FACING UP.
  - c. Set up the distribution system.
    - a. Gravity Installations - A standard 4-inch perforated pipe, meeting Wisconsin Admin Code, is centered along the modules 4-foot length. Orifices are set at the 4 & 8 o'clock positions. All 4-inch pipes are secured with manufacturers supplied wire clamps, one per module.
    - b. Pressure Installations - A standard 4-inch perforated pipe, SDR 35 or equivalent, is centered along the modules 4-foot length. Orifices are set at the 4 & 8 o'clock positions. Insert a low pressure pipe (LPP) into the standard 4-inch perforated pipe. The LPP orifices are set at the 12 o'clock position. All 4-inch pipes are secured to the modules with manufacturers supplied wire clamps, one per module. Orifice shields are also permitted on the pressure distribution pipe, one per module.
  - d. Install vent pipe, if one is to be installed as prescribed in Table 3.
  - e. Spread Eljen cover fabric lengthwise over the pipe and drape over the sides of the GSF module rows. Secure in place with Specified Sand between and along the sides of the modules. Avoid blocking holes in perforated pipe by placing the cover fabric over the pipe prior to placing fill over the modules.
  - f. Place 6 inches minimum of Specified Sand along both sides of the modules edge. A minimum of 6 inches of Specified Sand is placed at the beginning and end of each row.
  - g. Complete backfill with topsoil, 12 inches minimum of cover over the GSF modules. Backfill exceeding 18 inches requires venting at the distal end of the system. Fill must be clean, porous and devoid of rocks. Do not use wheeled equipment over the system during backfill operation. A light track machine may be used with extreme caution, avoiding crushing or shifting of pipe assembly. Divert surface runoff. Finish grade to prevent surface ponding. Use backfill material that is soil suitable for the growth of vegetation, and be seeded to control erosion.

## VIII. OPERATION, MAINTENANCE AND PERFORMANCE MONITORING

- A. The GSF system owner is responsible for the operation and maintenance of the component. The county, department or POWTS service contractor may make periodic inspections of the components, checking for surface discharge, effluent levels, etc.

The owner or owner's agent is required to submit necessary maintenance reports to the appropriate jurisdiction and/or the department.

- B. Design approval and site inspections before, during, and after the construction are accomplished by the county or other appropriate jurisdictions in accordance to ch. SPS 383 of the Wis. Adm. Code.
- C. Routine and preventative maintenance aspects:
  - 1. Septic and distribution tanks are to be inspected routinely and maintained when necessary in accordance with their approvals.
  - 2. The effluent filter on shall be cleaned as required.
  - 3. Inspections of the in-ground GSF system performance are required at least once every three years. These inspections include checking the liquid levels in the observation pipes and examination for any seepage around the GSF system.
  - 4. Winter traffic on the soil absorption system is not advised to avoid frost penetration and to minimize compaction.
  - 5. A good water conservation plan within the house or establishment will help assure that the GSF system will not be overloaded.
- D. User's Manual: A user's manual is to accompany the GSF system. The manual is to contain the following as a minimum:
  - 1. Diagrams of all components and their location. This should include the location of the reserve area, if one is provided.
  - 2. Names and phone numbers of local health authority, component manufacturer or POWTS service contractor to be contacted in the event of component failure or malfunction.
  - 3. Information on the periodic maintenance of the component, including electrical/mechanical components.
  - 4. Information on limited activities on reserve area if provided.
- E. Performance monitoring must be performed on GSF systems installed under this manual.
  - 1. The frequency of monitoring must be:
    - a. At least once every three years following installation and,
    - b. At time of problem, complaint, or failure.
  - 2. The minimum criteria addressed in performance monitoring of GSF systems are:
    - a. Type of use.
    - b. Age of system.
    - c. Nuisance factors, such as odors or user complaints.

- d. Mechanical malfunction within the system including problems with valves or other mechanical or plumbing components.
- e. Material fatigue or failure, including durability or corrosion as related to construction or structural design.
- f. Neglect or improper use, such as exceeding the design rate, poor maintenance of vegetative cover, inappropriate cover over the system, or inappropriate activity over the system.
- g. Installation problems such as compaction or displacement of soil, improper orientation or location.
- h. Pretreatment component maintenance, including dosing frequency, structural integrity, groundwater intrusion or improper sizing.
- i. Dose chamber maintenance, including improper maintenance, infiltration, structural problems, or improper sizing.
- j. Distribution piping network, including improper maintenance or improper sizing.
- k. Ponding in distribution cell, prior to the pump cycle, is evidence of development of a clogging mat or reduced infiltration rates.
- l. Siphon or pump malfunction including dosing volume problems, pressurization problems, breakdown, burnout, or cycling problems.
- m. Overflow/seepage problems, as shown by evident or confirmed sewage effluent, including backup if due to clogging.

3. Reports are to be submitted in accordance with ch. SPS 383, Wis. Adm. Code.

## IX. REFERENCES

R.J. Otis, G.D. Plews and D.H. Patterson. "Design of Conventional Soil Absorption Trenches and Beds." In: Home Sewage Treatment, Proceeding of the Second National Home Sewage Treatment Symposium, ASAE Publication 5-77.

United States EPA, EPA 625/1-80-012, October 1980. "Design Manual – Onsite Wastewater Treatment and Disposal Systems."

X. GSF IN-GROUND WORKSHEET

A. SITE CONDITIONS

Evaluate the site and soils report for the following:

- Surface water movement.
- Measure elevations and distances on the site so that slope, contours and available areas can be determined.
- Description of several soil profiles where the component will be located.
- Determine the limiting conditions such as bedrock, high groundwater level, soil permeability, and setbacks.

Slope - \_\_\_\_%

Occupancy – One or Two-Family Dwelling - \_\_\_\_ (# of bedrooms)

Public Facility - \_\_\_\_\_ gal/day (Estimated wastewater flow)

Depth to limiting factor - \_\_\_\_\_ inches

Minimum depth of unsaturated soil required by Table 383.44-3, Wis. Adm. Code - \_\_\_\_\_ inches

In situ soil application rate used - \_\_\_\_\_ gal/ft<sup>2</sup>/day

FOG value of effluent applied to component - \_\_\_\_\_ mg/L

Treated Effluent from Component

BOD<sub>5</sub> value of effluent leaving the component - ≤ 30 TSS mg/L TSS

value of effluent leaving the component - ≤ 30 mg/L

Fecal Coliform monthly geometric mean value of effluent applied to component > 10<sup>4</sup> cfu/100ml X No

Product(s) to be installed in one laying length of distribution cell -

Table 2c APPROVED PRODUCT INSTALLATIONS AND SQUARE FOOTAGE				
Product	Square Footage	Installation Width	Installation Length	Install Height
A42	12 square feet per unit	36"	48"	19"
	16 square feet per unit	48"	48"	19"
	20 square feet per unit	60"	48"	19"
B43	16 square feet per unit	48"	48"	19"
	20 square feet per unit	60"	48"	19"
	24 square feet per unit	72"	48"	19"

B. DESIGN WASTEWATER FLOW (DWF)

One or Two-family Dwelling.

Combined wastewater flow:

DWF = 150 gal/day/bedroom x # of bedrooms

= 150 gal/day/bedroom x \_\_\_\_ # of bedrooms

= \_\_\_\_\_ gal/day



Clearwater and graywater only:

$$\begin{aligned} \text{DWF} &= 90 \text{ gal/day/bedroom} \times \# \text{ of bedrooms} \\ &= 90 \text{ gal/day/bedroom} \times \text{_____} \# \text{ of bedrooms} \\ &= \text{_____} \text{ gal/day} \end{aligned}$$

Blackwater only:

$$\begin{aligned} \text{DWF} &= 60 \text{ gal/day/bedroom} \times \# \text{ of bedrooms} \\ &= 60 \text{ gal/day/bedroom} \times \text{_____} \# \text{ of bedrooms} \\ &= \text{_____} \text{ gal/day} \end{aligned}$$

Public Facilities.

$$\begin{aligned} \text{DWF} &= \text{Estimated wastewater flow} \times 1.5 \\ &= \text{_____} \text{ gal/day} \times 1.5 \\ &= \text{_____} \text{ gal/day} \end{aligned}$$

C. DESIGN OF THE GSF SECTION DISTRIBUTION CELL

1. Determine the design loading rate (DLR) for the site.

From Table 383.44-1 or-2, Wis. Adm. Code, select the soil application rate for the most restrictive soil horizon at the infiltrative surface or a lower horizon if the lower horizon adversely affects the dispersal of wastewater in accordance with s. SPS 383.44 (4) (a) and (c). The design loading rate (DLR) is the soil application rate selected from Table 383.44-1 or-2, Wis. Adm. Code, unless the component consists of products that have been recognized through s. SPS 384.50, Wis. Adm. Code, as having a different soil application rate.

$$\text{DLR} = \text{_____} \text{ gpd/ft}^2$$

2. Total size of the Distribution cell(s) area

Calculate the distribution cell area by dividing the daily design wastewater flow (DWF) by the design loading rate (DLR).

$$\begin{aligned} \text{Distribution cell area} &= \text{DWF} \div \text{DLR} \\ \text{Distribution cell area} &= \text{_____} \text{ gpd} \div \text{_____} \text{ gpd/ft}^2 \\ \text{Distribution cell area} &= \text{_____} \text{ ft}^2 \end{aligned}$$

3. The product selected determines the minimum trench width.

Table 2c APPROVED PRODUCT INSTALLATIONS AND SQUARE FOOTAGE				
Product	Square Footage	Installation Width	Installation Length	Install Height
A42	12 square feet per unit	36"	48"	19"
	16 square feet per unit	48"	48"	19"
	20 square feet per unit	60"	48"	19"
B43	16 square feet per unit	48"	48"	19"
	20 square feet per unit	60"	48"	19"
	24 square feet per unit	72"	48"	19"

$$A = \text{_____} \div 12 \text{ in/ft} = \text{_____} \text{ ft}$$

4. Determine the total distribution cell length.

Calculate the total distribution cell length (B) by dividing the required distribution area by the distribution cell width (A).

$$B = \text{Distribution cell area} \div A$$

$$B = \text{_____} \text{ ft}^2 \div \text{_____} \text{ ft}$$

$$B = \text{_____} \text{ ft}$$

Final Dimensions = A, B

$$\text{_____} \text{ ft, _____} \text{ ft}$$

XI. EXAMPLE GSF IN-GROUND WORKSHEET

A. SITE CONDITIONS

Evaluate the site and soils report for the following:

- Surface water movement.
- Measure elevations and distances on the site so that slope, contours and available areas can be determined.
- Description of several soil profiles where the component will be located.
- Determine the limiting conditions such as bedrock, high groundwater level, soil permeability, and setbacks.

Slope - \_\_\_\_%

Occupancy – One or Two-Family Dwelling - 4 (# of bedrooms)

Public Facility - \_\_\_\_\_ gal/day (Estimated wastewater flow)

Depth to limiting factor - 60 inches

Minimum depth of unsaturated soil required by Table 383.44-3, Wis. Adm. Code - 36 inches

In situ soil application rate used - 0.8 gal/ft<sup>2</sup>/day

FOG value of effluent applied to component - 20 mg/L

Treated Effluent from Component

BOD<sub>5</sub> value of effluent leaving the component -  $\leq 30$  TSS mg/L TSS

value of effluent leaving the component -  $\leq 30$  mg/L

Fecal Coliform monthly geometric mean value of effluent applied to component  $> 10^4$  cfu/100ml X No

Product(s) to be installed in one laying length of distribution cell -

Table 2c APPROVED PRODUCT INSTALLATIONS AND SQUARE FOOTAGE				
Product	Square Footage	Installation Width	Installation Length	Install Height
A42	12 square feet per unit	36"	48"	19"
	16 square feet per unit	48"	48"	19"
	20 square feet per unit	60"	48"	19"
B43	16 square feet per unit	48"	48"	19"
	20 square feet per unit	60"	48"	19"
	24 square feet per unit	72"	48"	19"

B. DESIGN WASTEWATER FLOW (DWF)

One or Two-family Dwelling.

Combined wastewater flow:

DWF = 150 gal/day/bedroom x # of bedrooms

= 150 gal/day/bedroom x 4 # of bedrooms

= 600 gal/day

Clearwater and graywater only:

$$\begin{aligned} \text{DWF} &= 90 \text{ gal/day/bedroom} \times \# \text{ of bedrooms} \\ &= 90 \text{ gal/day/bedroom} \times \underline{\hspace{2cm}} \# \text{ of bedrooms} \\ &= \underline{\hspace{2cm}} \text{ gal/day} \end{aligned}$$

Blackwater only:

$$\begin{aligned} \text{DWF} &= 60 \text{ gal/day/bedroom} \times \# \text{ of bedrooms} \\ &= 60 \text{ gal/day/bedroom} \times \underline{\hspace{2cm}} \# \text{ of bedrooms} \\ &= \underline{\hspace{2cm}} \text{ gal/day} \end{aligned}$$

Public Facilities.

$$\begin{aligned} \text{DWF} &= \text{Estimated wastewater flow} \times 1.5 \\ &= \underline{\hspace{2cm}} \text{ gal/day} \times 1.5 \\ &= \underline{\hspace{2cm}} \text{ gal/day} \end{aligned}$$

C. DESIGN OF THE GSF SECTION DISTRIBUTION CELL

4. Determine the design loading rate (DLR) for the site.

From Table 383.44-1 or-2, Wis. Adm. Code, select the soil application rate for the most restrictive soil horizon at the infiltrative surface or a lower horizon if the lower horizon adversely affects the dispersal of wastewater in accordance with s. SPS 383.44 (4) (a) and (c). The design loading rate (DLR) is the soil application rate selected from Table 383.44-1 or-2, Wis. Adm. Code, unless the component consists of products that have been recognized through s. SPS 384.50, Wis. Adm. Code, as having a different soil application rate.

$$\text{DLR} = \underline{0.8} \text{ gpd/ft}^2$$

5. Total size of the Distribution cell(s) area

Calculate the distribution cell area by dividing the daily design wastewater flow (DWF) by the design loading rate (DLR).

$$\begin{aligned} \text{Distribution cell area} &= \text{DWF} \div \text{DLR} \\ \text{Distribution cell area} &= \underline{600} \text{ gpd} \div \underline{0.8} \text{ gpd/ft}^2 \\ \text{Distribution cell area} &= \underline{750} \text{ ft}^2 \end{aligned}$$

3. The product selected determines the minimum trench width.

Table 2c APPROVED PRODUCT INSTALLATIONS AND SQUARE FOOTAGE				
Product	Square Footage	Installation Width	Installation Length	Install Height
A42	12 square feet per unit	36"	48"	19"
	16 square feet per unit	48"	48"	19"
	20 square feet per unit	60"	48"	19"
B43	16 square feet per unit	48"	48"	19"
	20 square feet per unit	60"	48"	19"
	24 square feet per unit	72"	48"	19"

$$A = \underline{36} \div 12 \text{ in/ft} = \underline{3} \text{ ft}$$

4. Determine the total distribution cell length.

Calculate the total distribution cell length (B) by dividing the required distribution area by the distribution cell width (A).

$$B = \text{Distribution cell area} \div A$$

$$B = \underline{750} \text{ ft}^2 \div \underline{3} \text{ ft}$$

$$B = \underline{250} \text{ ft}$$

$$\text{Final Dimensions} = A, B$$

$$\underline{3} \text{ ft}, \underline{250} \text{ ft}$$

## XII. PLAN SUBMITTAL AND INSTALLATION INSPECTION

### A. Plan Submittal

In order to install a system correctly, it is important to develop plans that will be used to install the system correctly the first time. The following checklist may be used when preparing plans for review. The checklist is intended to be a **general guide**. Not all needed information may be included in this list. Some of the information may not be required to be submitted due to the design of the system. Conformance to the list is not a guarantee of plan approval. Additional information may be needed or requested to address unusual or unique characteristics of a particular project. Contact the reviewing agent for specific plan submittal requirements, which the agency may require that are different than the list included in this manual.

#### General Submittal Information

- Photocopies of soil report forms, plans, and other documents are acceptable. However, an original signature is required on certain documents.
- Submittal of additional information requested during plan review or questions concerning a specific plan must be referenced to the Plan Identification indicator assigned to that plan by the reviewing agency.
- Plans or documents must be permanent copies or originals.

#### Forms and Fees

- Application form for submittal, provided by reviewing agency along with proper fees set by reviewing agent.

#### Soils Information

- Complete Soils and Site Evaluation Report (form # SBD-8330) for each soil boring described; signed and dated by a certified soil tester, with license number.
- Separate sheet showing the location of all borings. The location of all borings and backhoe pits must be able to be identified on the plot plan.

#### Documentation

- Architects, engineers or designers must sign, seal and date each page of the submittal or provide an index page, which is signed, sealed and dated.
- Master Plumbers must sign, date and include their license number on each page of the submittal or provide an index page, which is signed, sealed and dated.
- Three completed sets of plans and specifications (clear, permanent and legible); submittals must be on paper measuring at least 8-1/2 by 11 inches.
- Designs that are based on department approved component manual(s) must include reference to the manual by name, publication number and published date.

#### Plot Plan

- Dimensioned plans or plans drawn to scale (scale indicated on plans) with parcel size or all property boundaries clearly marked.
- Slope directions and percent in system area.
- Bench mark and north arrow.
- Setbacks indicated as per appropriate code.
- Two-foot contours or other appropriate contour interval within the system area.
- Location information; legal description of parcel must be noted.

- Location of any nearby existing system or well.

#### Plan View

- Dimensions for distribution cell(s).
- Location of observation pipes and vent pipes if required.
- Pipe lateral layout, which must include the number of laterals, pipe material, diameter and length; and number, location and size of orifices.
- Distribution boxes, drop boxes, manifold and force main locations, with materials, length and diameter of all pipes.

#### Cross Section of System

- Lateral elevation, position of observation pipes, dimensions of distribution cell, and type of cover material such as geotextile fabric, if applicable.
- Distribution cell details
- Minimum and maximum depths of top of the GSF unit below original and final grades.

#### System Sizing

- For one and two-family dwellings, the number of bedrooms must be included.
- For public buildings, the sizing calculations must be included.

#### Tank And Pump or Siphon Information

- Cross-section and all construction details for site-constructed tanks.
- Size, model and manufacturer information for prefabricated tanks.
- Notation of pump or siphon model, pump performance curve, friction loss for force main and calculation for total dynamic head.
- Notation of alarm manufacturer and model number.
- Cross section of dose tank / chamber to include storage volumes; connections for piping, vents, and power; pump "off" setting; dosing cycle and volume, high water alarm setting, and storage volume above the highwater alarm; and location of vent and manhole.

#### B. Inspections

Inspection shall be made in accordance with ch. 145.20, Wis. Stats. and s. SPS 383.26, Wis. Adm. Code. The inspection form on the following two pages may be used. The inspection of the system installation and/or plans is to verify that the system at least conforms to specifications listed in Tables 1 - 3 of this manual.

XIII. POWTS INSPECTION REPORT

(ATTACH TO PERMIT)

**GENERAL INFORMATION**

Permit Holder's Name		<input type="checkbox"/> City <input type="checkbox"/> Village <input type="checkbox"/> Town of		County		Sanitary Permit No.	
State Plan ID No.		Tax Parcel No.		Property Address if Available			
<b>TREATMENT COMPONENT INFORMATION</b>				<b>SETBACKS (FT)</b>			
TYPE	MANUFACTURER AND MODEL NUMBER	CAPACITY	P/L	WELL	WATER LINE	BLDG.	VENT
SEPTIC							
DOSING							
AERATION							
HOLDING							
FILTER							

**PUMP / SIPHON INFORMATION**

Manufacturer:		Model No.		Demand in GPM		TDH - Design	
<b>FORCE MAIN INFORMATION</b>				<b>FRICTION LOSS (FT)</b>			
Length	Diameter	Dist. To Well	Component Head	Force Main Losses	Vert. Lift	TDH - As Built	

**SOIL ABSORPTION COMPONENT**

<b>TYPE OF COMPONENT:</b>				<b>COVER MATERIAL:</b>			
Cell Width	Cell Length	Cell Depth	Cell Spacing	No. of Cells			
UNIT		Manufacturer: <u>Eljen Corporation</u>			Model No.		
SETBACK INFO. (FT)	Property Line	Bldg.	Well	Water Line			

**DISTRIBUTION COMPONENT**

Elevation data on back of form

Header / Manifold		Distribution Lateral(s)			Orifice size	Orifice Spacing	Obs. Pipes Inst. & No.
Length	Dia.	Length	Dia.	Spacing			

**SOIL COVER**

Depth over center of cell:	Depth over edge of cell:	Depth of Cover material	Texture	Seeded / Sodded	Mulched
----------------------------	--------------------------	-------------------------	---------	-----------------	---------

**DEVIATIONS FROM APPROVED PLAN**

DATE OF INST. DIRECTIVE:		DATE OF ENFORCEMENT ORDER:	
DATE OF REFERRAL TO LEGAL COUNSEL:			

**COMMENTS (Persons present, discrepancies, etc.)**

<b>COMMENTS NOT INSPECTED</b>	
-------------------------------	--

Plan Revision Required <input type="checkbox"/> Yes <input type="checkbox"/> No	Date:	Signature of Inspector:	Cert. Number
--	-------	-------------------------	--------------

Sketch on other side



**ELEVATION DATA**

<b>Point</b>	<b>Back sight</b>	<b>Height of instrument</b>	<b>Foresight</b>	<b>Elevation</b>	<b>Comments</b>
<b>Bench mark</b>					
<b>Bldg. Sewer</b>					
<b>Tank inlet</b>					
<b>Tank outlet</b>					
<b>Tank inlet</b>					
<b>Tank outlet</b>					
<b>Dose tank</b>					
<b>Bottom of dose</b>					
<b>Dist. lateral 1</b>					
<b>System elev. 1</b>					
<b>Dist. lateral 2</b>					
<b>System elev. 2</b>					
<b>Dist. lateral 3</b>					
<b>System elev. 3</b>					
<b>Grade elev. 1</b>					
<b>Grade elev. 2</b>					
<b>Grade elev. 3</b>					

**SKETCH OF COMPONENT & ADDITIONAL COMMENT**